

COMPACT

FARMTRAC 25G



OPERATOR MANUAL

INTRODUCTION

----- To Users -----

Escorts Kubota Limited appreciates your selection of FARMTRAC 25G tractor for your application.

No one should operate the tractor unless they read and understand the information in this manual.

This manual contains the instructions and data on the safety and operation of the tractor. Follow the operation procedures to make sure that your tractor operates at **MAXIMUM EFFICIENCY**. The operator must keep this manual in the cab of the tractor.

If there is anything in the manual that is not clear or you do not understand, please contact our service technician. We (Escorts Kubota Limited) are **NOT** responsible for damages from / to any operator's actions who operates the tractor.

The **OPERATOR'S MANUAL** is an important part of the tractor and shall be read and followed by every person operating the tractor.

The data (data, specifications, illustrations) in this manual is for tractor in production at the time of this manual's publication. We reserve the right to make changes to this manual at any time, without obligation.

Thank you!

OFAGMCNEB1

December 7th, 2022

INTRODUCTION

Thank you for purchasing your new Farmtrac tractor. :

This Manual has been prepared to assist you in the correct procedure for running-in, driving and operating your new tractor and to assist you in the correct method of maintenance to keep it in peak condition.

Your tractor has been designed and built to give maximum performance, better productivity and ease of operation under a wide variety of operating conditions. Prior to delivery, the tractor was carefully inspected, both at the factory and by your Authorized Dealer to ensure that it reaches you in optimum condition. To maintain this condition and ensure trouble-free operation, it is important that the routine services, as specified in this manual, are carried out at the recommended intervals.

The precautions to be observed to ensure your safety and the safety of others. Read the safety precautions and follow the advice offered before operating the tractor.

The vehicle reference serial number are also recorded on the pre-delivery inspection sheet that was provided to you by your Authorized Dealer and should be quoted to the Dealer when the tractor require service.

Read this Manual carefully and keep it at a convenient place for future reference. This manual must be considered as an integral part of your tractor. If at any time you require service or advice concerning your tractor, do not hesitate to contact your Authorized Dealer. He has trained personnel, genuine parts and the necessary equipment to carry out all your service requirements.

Following these introductory pages, this manual is split into three sections. Section A describes the controls and instruments and advises the correct method of operating your new tractor. Section B details lubrication and maintenance procedures and includes a comprehensive service chart. Section C outlines the specifications of your tractor.

Escorts Kubota Limited has a Company policy of continuous improvement and development. Designs, materials and/or specifications are subject to change without notice and without any liability whatsoever.

All data given in this book is subject to production variations. Dimensions and weights are approximate only and the illustrations do not necessarily show tractor in standard condition. Some of the equipment/accessories described in the text may also not be fitted on your tractor. For exact information about any particular tractor, please consult your Authorized Dealer.

ESCORTS KUBOTA LIMITED

International Business Department

Plot No. 2 Sector-13, Faridabad - 121007, India

Phone : +91-0129-2575292/5507

E-mail : internatational@escorts.co.in

Website : www.escortsagri.com

ABBREVIATION LIST

Abbreviations	Definitions
2WD	2-Wheel Drive
4WD	4-Wheel Drive
FPM	Feet Per Minute
H-M-L	High -Medium-Low Speed
m/s	Meters Per Second
PTO	Power Take Off
RH/LH	Right-hand and left-hand sides are determined by facing in the direction of forward travel
ROPS	Roll-Over Protective Structures
RPM	Revolutions Per Minute
R/s	Revolutions Per Second
SMV	Slow Moving Vehicle
RCD	Residual Charge Device
MSD	Manual Service Disconnect Switch
SOC	State of charge
BMS	Battery management system.

FOREWORD

You are now the proud owner of FARMTRAC Tractor. This tractor is a product of FARMTRAC quality engineering and manufacturing. It is made of fine materials and under a rigid quality control system. It will give you long, satisfactory service. To obtain the best use of your tractor, please read this manual carefully. It will help you become familiar with the operation of the tractor and contains many helpful hints about tractor maintenance. It is FARMTRAC'S policy to utilize as quickly as possible every advance in our research. The immediate use of new techniques in the manufacturing of products may cause some small parts of this manual to be outdated. FARMTRAC distributors and dealers will have the most up-to-date information. Please do not hesitate to consult with them.



California Proposition 65

WARNING

Certain vehicle components and fluids, contain or emit chemicals known to the state of California to cause cancer and birth defects or other reproductive harm.

SAFETY FIRST

This symbol, the industry's "Safety Alert Symbol", is used throughout this manual and on labels on the machine itself to warn of the possibility of personal injury. Read these instructions carefully. It is essential that you read the instructions and safety regulations before you attempt to assemble or use this unit.

-  **DANGER :** Indicates an imminently hazardous situation which, if not avoided, will result in death or serious injury.
-  **WARNING :** Indicates a potentially hazardous situation which, if not avoided, could result in death or serious injury.
-  **CAUTION :** Indicates a potentially hazardous situation which, if not avoided, could result in minor or moderate injury.
- IMPORTANT:** Indicates that equipment or property damage could result if instructions are not followed.
- NOTE :** Gives helpful information.

OWNER'S ADDRESS AND TRACTOR IDENTIFICATION

OWNER'S NAME &

.....

ADDRESS

.....

Ph.....Mobile.....

BATTERY SR. NO.

.....

TRACTOR SERIAL NO.

.....

DATE OF INSTALLATION

.....

PURCHASED FROM
(DEALERS'S STAMP)



DELIVERY CERTIFICATE

1. Customer Name : 7. Mobile No. :
: 8. Model :
2. Address : 9. Tractor Sr. No. :
: 10. Engine No. :
3. State : 11. Date of Delivery :
4. Country : 12. Dealer Code :
5. Zip Code : 13. Dealer Name :
6. E-mail : 14. Location :

* Escorts Kubota Copy

INSTALLATION CERTIFICATE

1. Customer Name : 8. Tractor Application :
: 9. Delivery Invoice No. :
2. Address : 10. Date of Delivery :
: 11. Model :
3. State : 12. Tractor Sr. No. :
4. Country : 13. Engine No. :
5. Zip Code : 14. Installation Date :
6. E-mail :
7. Mobile No. :

Note : The Operator manual is given to me & I confirm that I will follow recommended maintenance and usage process as mentioned in the Operator manual.

Dealer Code

Dealer Stamp & Signature

15. Customer's Signature.....

* Escorts Kubota Copy

Tear off

Tear off

DELIVERY CERTIFICATE

Tear off

1. Customer Name :	7. Mobile No. :
2. Address :	8. Model :
3. State :	9. Tractor Sr. No. :
4. Country :	10. Engine No. :
5. Zip Code :	11. Date of Delivery :
6. E-mail :	12. Dealer Code :
	13. Dealer Name :
	14. Location :

* Dealer Copy

INSTALLATION CERTIFICATE

Tear off

1. Customer Name :	8. Tractor Application :
2. Address :	9. Delivery Invoice No. :
3. State :	10. Date of Delivery :
4. Country :	11. Model :
5. Zip Code :	12. Tractor Sr. No. :
6. E-mail :	13. Engine No. :
7. Mobile No. :	14. Installation Date :

Note : The Operator manual is given to me & I confirm that I will follow recommended maintenance and usage process as mentioned in the Operator manual.

Dealer Code <input type="text"/> <input type="text"/> <input type="text"/> <input type="text"/> <input type="text"/> <input type="text"/>
Dealer Stamp & Signature

15. Customer's Signature.....

* Dealer Copy

DELIVERY CERTIFICATE

1. Customer Name : 7. Mobile No. :
: 8. Model :
2. Address : 9. Tractor Sr. No. :
: 10. Engine No. :
3. State : 11. Date of Delivery :
4. Country : 12. Dealer Code :
5. Zip Code : 13. Dealer Name :
6. E-mail : 14. Location :

* Customer Copy

INSTALLATION CERTIFICATE

1. Customer Name : 8. Tractor Application :
: 9. Delivery Invoice No. :
2. Address : 10. Date of Delivery :
: 11. Model :
3. State : 12. Tractor Sr. No. :
4. Country : 13. Engine No. :
5. Zip Code : 14. Installation Date :
6. E-mail :
7. Mobile No. :

Note : The Operator manual is given to me & I confirm that I will follow recommended maintenance and usage process as mentioned in the Operator manual.

Dealer Code

Dealer Stamp & Signature

15. Customer's Signature.....

* Customer Copy

Tear off

Tear off

CET Start-Up Procedure

- MSD switch should be in "ON" condition.
- Take the red removable 12V battery switch and as you sit down on the seat near your left heel there is a place to insert the switch and turn it clockwise.
- Fasten the seat belt and make sure that the F-N-R switch is in "N".
- Insert the key and turn clockwise. The Loader pump will make a fan noise and the dash lights will all come on and then go out leaving only the "N" and parking brake light "ON".
- Release the parking brake by turning the orange handle at the heel of your right foot so it drops down and the parking brake light should go out.
- Next press the power steering switch and the 3-point hitch switch below the steering wheel. Now you can lift the rear implement by pulling back hydraulic lever situated on the right fender.
- Finally shift into "L" - Low with the lever on the left fender and switch into F or R and press the foot throttle slowly to move the tractor.

CET Shut-Down Procedure

- Reverse the above procedure but you can leave the 12V battery switch in place and the hood does not need to be opened to turn off the main battery switch unless the tractor will not be used for several days after it is charged.
- The 12V battery switch must be turned "ON" when charging and running the tractor but should be turned "OFF" the rest of the time.

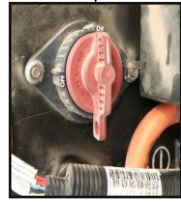

MSD Switch In "ON" Condition



12V Battery Switch In "ON" Condition

Compact Electric Tractor with 15 KW continuous and 43 kW peak motor controller

Major Components

Battery Pack

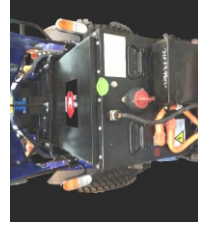

Battery Pack

Lithium-ion (NMC) 300 AH Battery pack at 72 VDC for 21 kWh of energy storage

Motor

15 KW, 3 Phase AC induction Motor



Induction Motor

Controller

200 Amp continuous, 600 Amp peak AC Motor Controller

Charger

15 Amp 230 VAC On Board Charger



Charger

DC-DC Converter

The 72 V to 12 V DC-DC Converter for charging the auxiliary battery and running other 12 V loads

Error codes for Controller and Battery

MOTOR CONTROLLER ERROR CODE

- 12 Controller Over Current
- 13 Current Sensor Fault
- 15 Controller Severe Undertemp
- 16 Controller Severe Over temp
- 17 Severe B+ Under voltage
- 18 Severe B+ Overvoltage
- 18 Severe KSI Overvoltage
- 22 Controller Over temp Cutback
- 23 B+ Under voltage Cutback
- 24 B+ Overvoltage Cutback
- 25 +5V Supply Failure
- 28 Motor Temp Hot Cutback
- 29 Motor Temp Sensor Fault
- 31 Coil1 Driver Open/Short
- 31 Main Open/Short
- 32 Coil2 Driver Open/Short
- 32 EM Brake Open/Short
- 36 Encoder Fault
- 36 Sin/Cos Sensor Fault
- 37 Motor Open
- 38 Main Contactor Welded
- 39 Main Contactor Did Not Close
- 41 Throttle Wiper High
- 42 Throttle Wiper Low
- 43 Pot2 Wiper High
- 44 Pot2 Wiper Low
- 45 Pot Low Over Current
- 46 EEPROM Failure
- 47 HPDI/Sequencing Fault
- 49 Parameter Change Fault
- 51 Vehicle lock without applying hand brake
- 72 PDO Timeout
- 73 Stall Detected
- 83 Driver Supply
- 87 Motor Characterization Fault
- 88 Encoder Pulse Count Fault
- 89 Motor Type Fault
- 92 EM Brake failed to set
- 99 Parameter Mismatch

BMS ERROR CODES

- 100 SOC is too high
- 101 SOC is too low
- 102 Total voltage is too high
- 103 Total voltage is too low
- 104 Charge current fault
- 105 Discharge current fault
- 106 Battery temperature is too low
- 107 Battery temperature is too high
- 108 Battery under voltage
- 109 Battery overvoltage
- 110 Battery temperature unbalance
- 111 Battery temperature unbalance
- 112 The battery does not match
- 113 The temperature of the output pole is too high
- 116 The parameters of memory fault
- 117 Data memory fault
- 118 Cell voltage detection fault
- 119 Temperature detection fault
- 120 Current detection fault
- 121 Internal total voltage detection fault
- 122 External total voltage detection fault
- 123 Insulation monitoring fault
- 124 Clock fault
- 125 Internal CAN communication fault
- 126 Serious insulation fault
- 127 Slight insulation fault
- 140 System fault level
- 142 BMS fault need maintenance
- 143 Battery fault need maintenance
- 144 Battery system fault needs maintenance
- 145 The battery needs to maintenance
- 146 Maintenance mode status

Tractor Controls SOP

Manual Service Disconnect (MSD) Switch

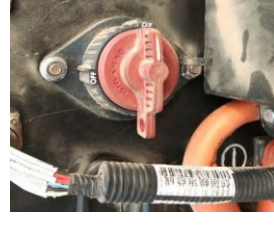

Manual Service Device Switch

Manual Service Disconnect On Battery Box – To Cut off the 72 Volt output from Battery Box

Key Switch

To switch On the System

Forward/Neutral/Reverse (FNR) Switch with Combination of Slow/Normal/Fast (SNF)

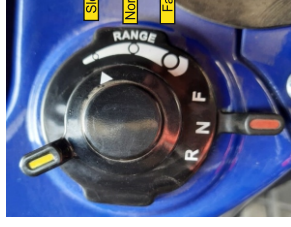

Range and FNR Switch

FNR Switch with Combination of SNF Switch:

- > FNR Switch – To select Forward/Reverse direction or Neutral
- > SNF Range Switch – To select motor RPM Range (S- <2000 RPM, N- <2500RPM, F- <2800RPM)

Tractor Controls

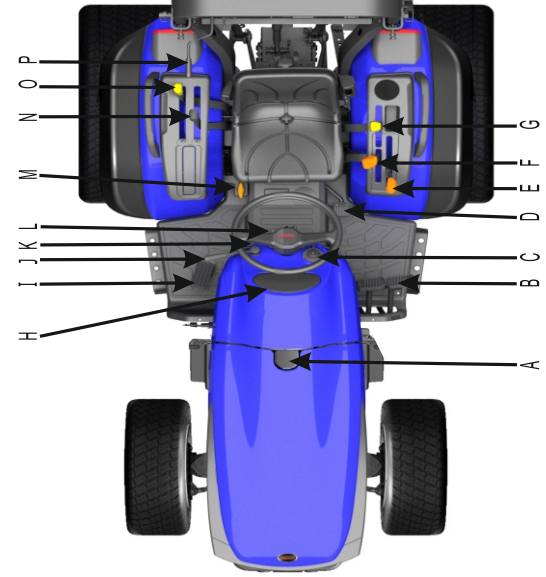

A	Charging Port
B	Brake Pedals
C	Combination Switch (lights, indicators & Horn)
D	Differential Lock Pedal
E	Range Lever (High, Neutral, Medium, Low)
F	2WD/4WD Lever
G	Rear PTO Lever
H	Instrument Cluster
I	Foot Throttle
J	Hand Throttle
K	SNF (Slow, Normal, Fast) & FIR Switch
L	Switch Panel
M	Parking Brake
N	Draft Control Lever
O	Position Control Lever
P	Auxiliary Valve Lever

Instrument Panel

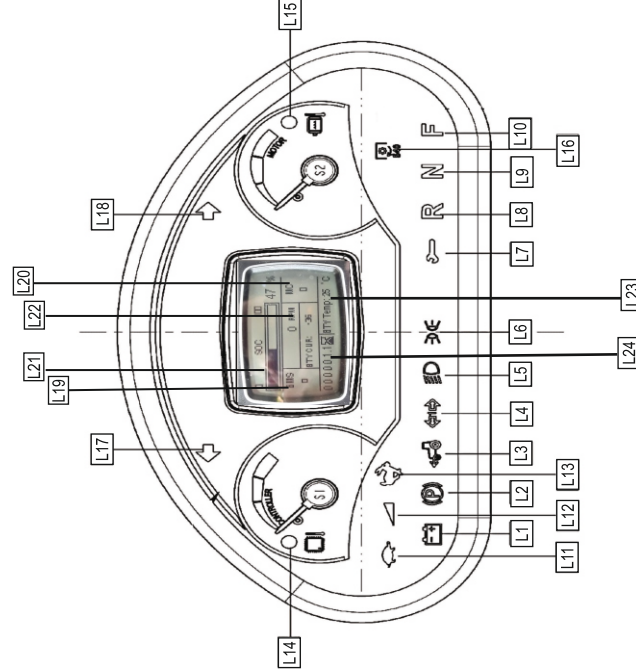

L1	Battery Charging
L2	Parking Brake
L3	4WD Engaged
L4	Turn Trailer
L5	Projector Lamp
L6	Position Lamp
L7	Malfunction
L8	Reverse
L9	Neutral
L10	Forward
L11	Low Throttle
L12	Throttle Low/Hi
L13	High Throttle
L14	Controller Temperature
L15	Motor Temperature
L16	Rear PTO
L17	Left Indicator
L18	Right Indicator
L19	BMS Error
L20	Motor Controller Error Code
L21	Battery State of Charge (SOC)
L22	Motor RPM
L23	Battery Temperature
L24	HMR

A. Pump on/off Switch

B. Lift Mode Selection Switch

When OFF – Motor will run on low RPM to use only Power Steering
When ON – RPM will increase and lift Operation can be used

C. PTO Wet Clutch

To engage the PTO
To start the auxiliary Hydraulic Pump Motor

D. Hazard Switch

Indicator Combination Switch

For left and right indicators
Turning headlamp on/off and Horn

Charging Port

Charging Port to plug in the charging cable

RCD (Residual Current Device) Charging Cable

The Charging Cable must be plugged into a 15 Amp 230V Socket to charge the tractor

Safety Features



MSD switch - To Cut off the 72 Volt output from Battery



Charging Interlock – prevents the tractor from operating when it is plugged in

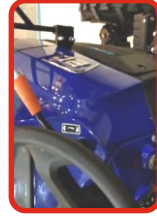

Reverse Mode speed limit – 2240 RPM (80% of the Max. RPM)
Reverse mode PTO Safety Interlock – PTO will not work in reverse mode

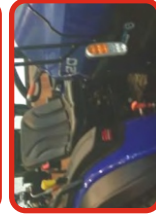

Safety Interlock – Main motor will not run if the throttle is not zero before start

Seat OPC – If driver gets down without engaging the parking brake, tractor system will automatically shut Off within 7 Sec

Pre Operation Check & Starting the Tractor

- Switch on the MSD Switch.
 - Sit on the tractor.
 - Check that both throttles are in zero position.
 - FNR switch should be in Neutral.
- (If key switch is turned "ON" and FNR switches in F or R mode, simply put FNR switch in neutral then select F/R mode. There is no need to turn off the key switch.)
- Parking brake must be disengaged.
 - Pump on/off switch should be "OFF"
- (If the key switch is turned "ON" and Pump switch is "ON", simply switch "OFF" the pumps switch and turn it back "ON". There is no need to turn off the key switch.)
- LMNH (Low-Medium-Neutral-Fast) Range lever should be in Neutral.
 - Tractor will start with SNF switch in any position, and (SNF switch can be put in any position while the ignition is "ON".)

BATTERY & WINTER CARE

Main and auxiliary Battery location on tractor

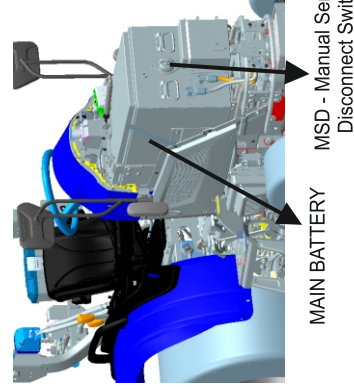

MAIN BATTERY

MSD - Manual Service Disconnect Switch

Battery Charging Procedure & Warning

Charge the vehicle in ventilated area, under a shade

Step 1- Put the tractor on Parking Brake and ensure MSD is ON.

Step 2- Check voltage of auxiliary battery with the help of ohmmeter. Voltage should be 11V to 14V. If voltage is below 11V, then charge the auxiliary battery.



MSD- "ON" POSITION

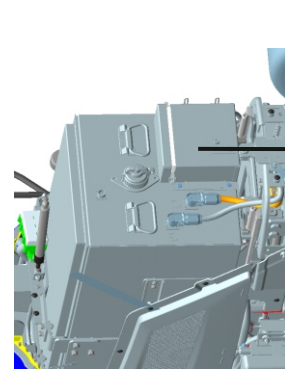

AUXILIARY BATTERY

Step 3- Plug the Cable into 15 Amp wall mounted socket and switch it ON.



Step 4- Plug the other end on vehicle side.



RCD Charging Cable Plugged In

Step 5- After Plug-in "Green light" will blink on RCD - Residual Charge Device, it will continue to blink if charging is happening.

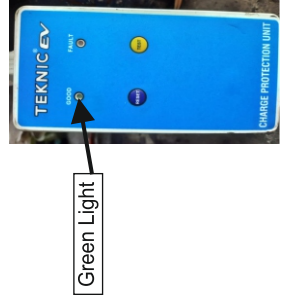

Green Light

RCD - Residual Charge Device

Step 6- Fan will start working on the charger side, if charging is ON.



(Charger & Fan) LHS of tractor

Step 7- Switch "ON" the ignition key, battery symbol will illuminate on cluster.

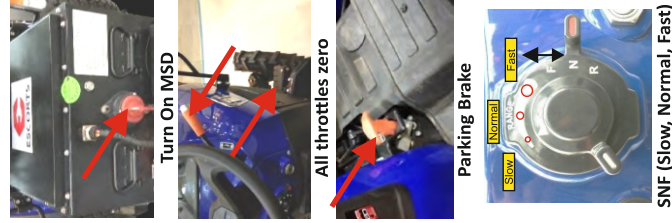

Turn On MSD

All throttles zero

Parking Brake

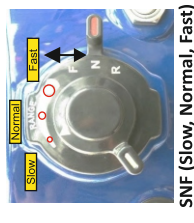

SNF (Slow, Normal, Fast)

General Warnings

Precautions while charging the battery –

- Do not charge the tractor in open area while it is raining or thundering.
- Do not plug-in or unplug the RCD plug with wet hands and do not stand in water, liquid or snow. This may cause an electric shock which may result in serious personal injury or death.
- Make sure the Charge port cap is closed when charging is completed. If the charger cord is removed and the cap is open, water or foreign materials may enter the charge port.
- Make sure there is no water or foreign materials in the charge port, charge connect or electrical plug, and that they are not damaged or effected by rust or Corrosion.
- Do not charge the tractor instantly after washing. Wait for 30 minutes so that tractor gets dry.

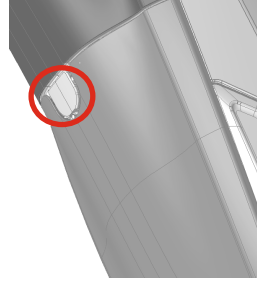

Charge port cap-Closed condition

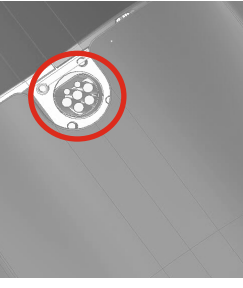

Charge port

Winter Care Instructions To Maintain Battery Operating Temperature In Operating Range

- After finishing the work, store tractor under the roof.
- In morning, check battery temperature at cluster, if temperature is less than 0°C then do not put for charge, first discharge the tractor till temperature rises up to 0°C then put for charging.
- If you want to store tractor for longer duration, then please remove Auxiliary battery connection & put MSD to "OFF" position & follow long storage procedure.
- Generally put tractor for charge in night so that battery temperature maintains a limit (easy to discharge in morning).

Battery charging procedure beyond 0°C

- Step 1** – Park the tractor in closed shed if ambient temperature is less than zero.
- Step 2** – Before charging the tractor, check the BMS (Battery Management System) temperature on cluster by making ignition key "ON".
- Step 3** – If BMS temperature is below 0°C, do not charge the tractor.
- Step 4** – Maintain the ambient temperature inside shed via heater / blower until BMS temperature increase to 0°C. Tractor can work in outside condition till -10 °C ambient condition and is not advisable to work below -10°C.

Washing the Tractor

- Tractor washing with pressure gun is not recommended
- Tractor washing can be done with slow running water
- Tractor is to be washed from outside only without opening the hood
- Battery Box is not to be washed, but can be cleaned with damp cloth or air jet
- Ensure all connectors are closed and wires are taped before washing
- Ensure the charging port cap is closed
- Ensure MSD is "OFF"

General Guidelines and Tractor Storage Considerations

- 1 **Tractor should be parked under cover when not in operation.**
- 2 **Avoid parking the tractor near fire or any other heat source.**
- 3 **Apply parking brake.**
- 4 **Fully charge the battery before storing the tractor for a long period.**
- 5 **Turn "OFF" the MSD and 12 V switch.**
- 6 **Charge the battery once within 3 months, if tractor is not in use.**
- 7 **Look for alerts and error codes on instrument panel.**
- 8 **Keep electrical components dust free.**
- 9 **Inspect and clean battery wires. Damaged or frayed wires should be replaced by a qualified technician.**
- 10 **Avoid using tractor during rainstorm.**
- 11 **Ensure all connectors are closed and wires are taped before washing.**
- 12 **Ensure the charging port cap is closed.**

BATTERY STORAGE PROCEDURE FOR LONG TIME

This procedure will help you to keep main battery (72VDC, 300AH) for longer time.

Important Safety Instructions

1. Keep battery away from any hazardous material such as corrosive chemicals, dangerous equipment, high-temperature environment.
2. Inappropriate use of the products may result in smoke, such as external short circuit, overcharge, high ambient temperature. If smoking occurs, turn off the power supply immediately and use carbon dioxide or dry powder fire extinguishers. Suggest to bury the battery with sand or soil if necessary. The whole process need to accompany timely evacuation alarm (if necessary).
3. In appropriate use of the products may lead to single cells bumping, severe cases may cause the Aluminum-plastic pouch breaks or cracks, immediately stop using the battery, please contact Sound on to Analysis the root cause and wait M/s Soundon detail.
4. Prohibit directly positive and negative short circuit, avoid contacting battery terminal by any metal or other conductive object other than a bolt and a conductive strip to contact the battery terminal. This may lead to personal injury or property damage.
5. Prohibit to charge battery without BMS or use non-approved Charger to charge the battery pack, this may cause personal injury or property damage.
6. Prohibit to immerse the battery into water or other conductive liquid, this may lead to personal injury or property damage.
7. Keep away the battery from children and people who don't have knowledge of Lithium ion battery safety use.

STORAGE RECOMMENDATIONS

If SOC <= 10%,	Charged immediately
If 10% < SOC <= 40%	Each 1 month periodic charging
If 40% < SOC <= 80%	Each 3 months, periodically charging
If 80% < SOC <= 100%	Each 6 months, periodically charging time

NOTE : Charging Source:

15 Ampere, 220 V , 4 kW (Only For Tractor Charging) e.g. If charging is being conducted at home, total Load Required = 4kW + Other Household loads.

How to increase battery life:

- Use the battery from full charge of 100 % to 20 % before charging again so that number of charging cycles can be kept to minimum.
- Keep MSD "OFF", when tractor is not in use or during long storage of tractor.
- Do not operate the tractor when battery temperature goes beyond 50 °C (Battery temperature is shown on cluster)

Handling of Charging Cable

- RCD should not be in hanging position while charging. It may lead to damage of cable due to RCD unit weight.
- Store charging cable carefully. Avoid the contact of charging cable with any sharp objects, it can damage the cable.
- Check charging cable thoroughly before putting in socket.

CONTENTS

CHAPTER 1 - TRACTOR IDENTIFICATION	1
1.1. CHASSIS SERIAL NUMBER	1
1.2. BATTERY SERIAL NUMBER.....	1
1.3. IDENTIFICATION PLATE	1
CHAPTER 2 - SAFE OPERATION	2
2.1 BEFORE OPERATING THE TRACTOR	2
2.2 ROPS	2
2.2.1 OPERATING FOLDABLE ROPS	3
2.2.2 TO FOLD THE ROPS	3
2.2.3 TO RAISE THE ROPS TO UPRIGHT POSITION	3
2.2.4 ADJUSTMENT OF FOLDABLE ROPS	3
2.3 SAFETY FEATURES	4
2.4 SAFETY FOR CHILDREN	4
2.5 OPERATING ON SLOPES	4
2.6 DRIVING THE TRACTOR ON THE ROAD	5
2.7 USING 3-POINT HITCH	5
2.8 DAILY CHECK	5
2.9 GENERAL WORKING INSTRUCTIONS	6
2.9.1 BOARDING AND LEAVING THE TRACTOR	6
2.10 WASHING INSTRUCTIONS	7
2.11 PARKING THE TRACTOR	7
2.12 CARE OF DANGER, WARNING AND CAUTION LABELS	7
CHAPTER 3 - SAFE NOTES.....	8
CHAPTER 4 - TRACTOR OVERVIEW & CONTROLS	11
4.1 TRACTOR OVERVIEW	11
4.2 INSTRUMENT CLUSTER & FUNCTIONS.	12
4.2.1 WARNING SYMBOLS & INDICATION ON INSTRUMENT CLUSTER	12
4.2.2 DIGITAL PANEL	14
4.3 MALFUNCTION TELL TAIL ON CLUSTER	14
4.4 DASH BOARD.....	14
4.4.1 FNR SWITCH	14
4.4.2 SNF RANGE SWITCH	14
4.5 DASH BOARD SWITCHES FUNCTIONS.	15
4.5.1 LIFT MODE SELECTION SWITCH.....	15
4.5.2 PUMP ON/OFF SWITCH.....	15
4.5.3 PTO WET CLUTCH SWITCH	15
4.5.4 HAZARD SWITCH	15
4.5.5 COMBINATION SWITCH	15
CHAPTER 5 - OPERATING THE TRACTOR	16
5.1 PRE CHECKS BEFORE STARTING THE TRACTOR.....	16
5.2 SELECTING THE TRAVEL SPEED.	17

CONTENTS

5.3	ADJUSTING THE OPERATOR'S POSITION.....	18
5.4	OPERATOR PRESENCE SWITCH	18
5.5	SELECTING LIGHT SWITCH POSITIONS.....	19
5.6	BRAKE PEDALS	19
5.7	4WD LEVER.....	20
5.8	HAND THROTTLE LEVER	20
5.9	DIFFERENTIAL LOCK	20
5.10	OPERATING ON SLOPES OR ROUGH TERRAIN	21
5.11	TRANSPORT THE TRACTOR SAFELY	21
5.12	ELECTRICAL OUTLET	21
5.13	PTO	21
5.13.1	PTO SELECTION LEVER.....	22
5.13.2	PTO OPERATION	22
5.14	PROCEDURE TO OPERATE TRACTOR	22
5.15	3-POINT HITCH & SWINGING DRAWBAR.....	23
5.15.1	3-POINT HITCH	24
5.15.2	TOP LINK MOUNTING HOLES	24
5.15.3	ATTACHING AND DETACHING IMPLEMENTS	24
5.15.4	LIFT ROD (LEFT & RIGHT)	24
5.15.5	TOP LINK	24
5.15.6	CHECK CHAIN	24
5.15.7	3-POINT HITCH CONTROL SYSTEM	25
5.16	HYDRAULIC SYSTEM	25
5.16.1	DRAFT CONTROL OPERATION	25
5.16.2	POSITION CONTROL OPERATION	25
5.16.3	AUTOMATIC DRAFT DEPTH CONTROL	25
5.17	TRANSPORT LOCK	26
5.18	AUXILIARY SPOOL VALVE	26
5.19	DRAWBAR	27
5.20	TYRES	27
5.21	INFLATION PRESSURE	27
5.22	WHEEL ADJUSTMENT	27
5.23	TYRES, WHEELS AND BALLAST	27
5.24	REAR WHEELS	28
CHAPTER 6 - BATTERY & WINTER CARE		29
6.1	BATTERY CHARGING PROCEDURE & WARNING	29
6.2	HOW TO INCREASE BATTERY LIFE	30
6.3	HANDLING OF CHARGING CABLE	30
6.4	GENERAL WARNINGS	30
6.5	WINTER CARE INSTRUCTIONS TO MAINTAIN BATTERY OPERATING TEMPERATURE IN OPERATING RANGE.....	30
6.6	BATTERY CHARGING PROCEDURE BEYOND 0°C	30

CONTENTS

6.7	DO'S & DON'T	31
6.8	WORKING OF CHARGING CIRCUIT	31
6.9	MAINTENANCE	32
6.10	TROUBLESHOOTING	32
6.11	BATTERY STORAGE PROCEDURE FOR LONG TIME	33
6.12	STORAGE RECOMMENDATIONS.....	33
CHAPTER 7 - WARRANTY & SERVICING OF TRACTOR.....		34
7.1	WARRANTY & SERVICING OF TRACTOR.....	35
CHAPTER 8 - IMPLEMENT RECOMMENDATIONS		36
8.1	IMPLEMENT RECOMMENDATIONS	36
CHAPTER 9 - SPECIFICATION		38
9.1	SPECIFICATION	38
9.2	TRACK WIDTH OPTIONS	41
CHAPTER 10 - LUBRICATION AND MAINTENANCE.....		43
10.1	SERVICE INTERVALS.....	43
10.2	HOW TO OPEN THE HOOD.....	44
10.3	DAILY CHECK.....	44
10.4	EVERY 50 HOURS	45
10.5	ON EVERY SERVICE	46
10.6	AUXILIARY BATTERY.....	46
10.7	AUXILIARY BATTERY CHARGING	46
10.8	AUXILIARY BATTERY CUT-OFF SWITCH.....	47
10.9	ADJUSTING BRAKE PEDAL	47
10.10	ADJUSTING TOE-IN	47
10.11	ADJUSTING PROCEDURE	48
10.12	ADJUSTING FRONT AXLE PIVOT (4WD).....	48
10.13	CHECKING HYDRAULIC STAINER	48
10.14	CHANGING TRANSMISSION FLUID	49
10.15	CHANGING FRONT AXLE CASE OIL	50
10.16	REPLACING LIGHT BULB.....	50
CHAPTER 11 - TROUBLE SHOOTING		51
11.1.	ERROR CODES FOR CONTROLLER AND BATTERY.....	51
11.2.	TROUBLESHOOTING - GEARBOX, REAR AXLE AND FRONT AXLE.....	52

CHAPTER - 1 TRACTOR IDENTIFICATION

1.1. CHASSIS SERIAL NUMBER

Chassis Serial Number is punched on the right hand side of front axle support.

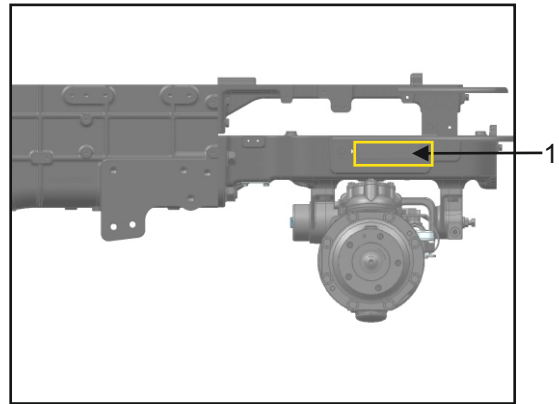

Fig. 1.1

1.2 BATTERY SERIAL NUMBER

Battery Serial Number & Battery Specifications are engraved on battery serial plate present on the front of battery (LH Side).

Battery Pack System

Model : : EV-012-73V350Ah-01
 Rated Voltage : 73V
 Rated Capacity : 350 Ah
 Working Voltage : DC60V~84V
 Rated Energy : 25.55kWh
 Total Weight : 180±15Kg

Soundon New Energy Technology co. Ltd.



Fig. 1.2

1.3. IDENTIFICATION PLATE

Chassis Serial number is also engraved on identification plate which is located on right hand side of tractor.

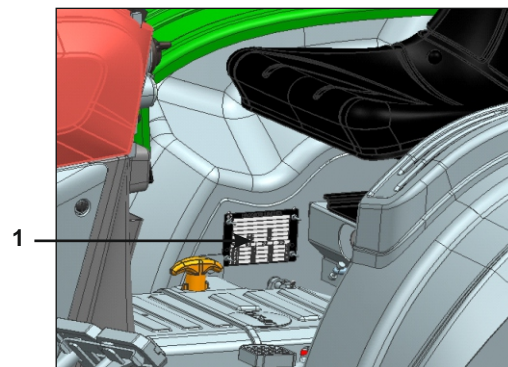

Fig. 1.3

CHAPTER -2 SAFE OPERATION

Careful operation is your best insurance against an accident.

Read and understand this manual carefully before operating the tractor.

All operators, no matter how much experience you may have, you should read this and other implement related manuals before operating the tractor or any implement attached to it. It is the owner's obligation to instruct all operators in safe operation.

2.1. BEFORE OPERATING THE TRACTOR

1. Know your equipment and its limitations. Read this entire manual before attempting to start and operate the tractor.
2. Pay special attention to the danger, warning and caution labels on the tractor.
3. Do not operate the tractor or any implement attached to it while under the influence of alcohol, medication, controlled substances or while fatigue.
4. Before allowing other people to use your tractor, explain how to operate and have them read this manual before operation.
5. Never wear loose, torn, or bulky clothing around tractor. It may catch on moving parts or controls, leading to the risk of an accident. Use additional safety items, e.g. hard hat, safety boots or shoes, eye and hearing protection, gloves, etc., as appropriate or required.
6. Do not allow passengers to ride on any part of the tractor at anytime. The operator must remain in the tractor seat during operation.
7. Check brakes, linkage pins and other mechanical parts for improper adjustment and wear. Replace worn or damaged parts promptly. Check the tightness of all nuts and bolts regularly. (For further details, see "MAINTENANCE" section.)
8. Keep your tractor clean. Dirt, grease, and trash build up may contribute to fires and lead to personal injury.
9. Use only implements meeting the specifications listed under " CHAPTER 8 IMPLEMENT RECOMMENDATIONS" in this manual or implements approved by FARMTRAC.
10. Use proper weights on the front of the tractor to reduce the risk of front lifting. When using the front loader, put an implement or ballast on the 3-point hitch to improve stability. Follow the safe operating procedures specified in the implement or attachment manual.
11. The narrower the track width , the greater the risk of a tractor upset. For maximum stability, adjust the wheels to the widest practical track width for your application. (See "chapter -9 track width options " section.)

12. Do not modify the tractor. Unauthorized modification may affect the function of the tractor, which may result in personal injury.

2.2. ROPS

1. FARMTRAC recommends the use of a Roll Over Protective Structures (ROPS) and seat belt in almost all applications. This combination will reduce the risk of serious injury or death, should the tractor be upset. Check for overhead clearance which may interfere with a ROPS.
2. Set parking brake and stop tractor. Remove any obstruction that may prevent raising or folding of the ROPS. Do not allow any bystanders. Always perform function from a stable position at the rear of the tractor. Hold the top of the ROPS securely when raising or folding. Make sure all pins are installed and locked.
3. If the ROPS is loosened or removed for any reason, make sure that all parts are reinstalled correctly before operating the tractor.
4. Never modify or repair any structural member of a ROPS because welding, bending, drilling, grinding, or cutting may weaken the structure.
5. If any structural member of the ROPS is damaged, replace the entire structure at your local FARMTRAC Dealer /Distributor.
6. If the tractor is equipped with a foldable ROPS it may be temporarily folded down only when absolutely necessary for areas with height constraints. (There is no operator protection provided by the ROPS in the folded position. For operator safety the ROPS should be placed in the upright and locked position and the seat belt fastened for all other operations.)
7. Always use the seat belt if the tractor has a ROPS. Do not use the seat belt if a foldable ROPS is down or there is no ROPS. Check the seat belt regularly and replace if frayed or damaged.

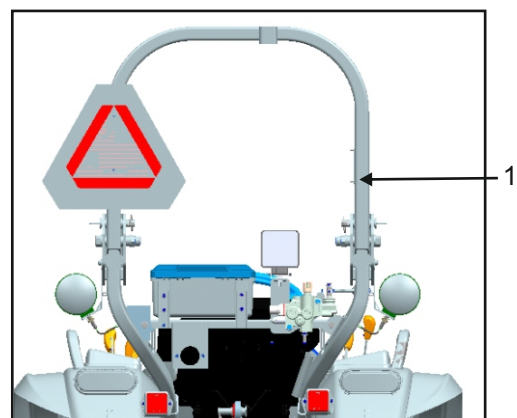

(1) ROPS

2.2.1 OPERATING FOLDABLE ROPS

⚠ WARNING

To avoid personal injury or death:

- When raising or folding the ROPS, apply parking brake, stop the tractor and remove the key. Always perform function in a stable position from the rear side of tractor.
- Fold the ROPS down only when absolutely necessary and fold it up and lock it again as soon as possible.
- Before proceeding to fold ROPS, check for any possible interference with installed implements and attachments. If interference occurs, contact your FARMTRAC Dealer/Distributor.

2.2.2 TO FOLD THE ROPS

1. Remove both ROPS mounting pins, maintain a hold on the ROPS.

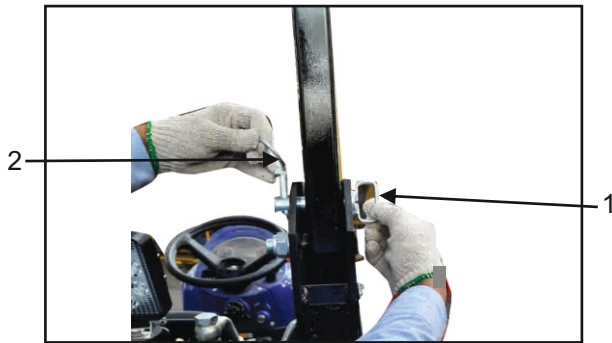

1. ROPS Mounting Pins 2. Lynch Pin

- Fold the ROPS.

⚠ CAUTION

To avoid personal injury:

- Hold the ROPS tightly with both hands and fold the ROPS slowly and carefully.

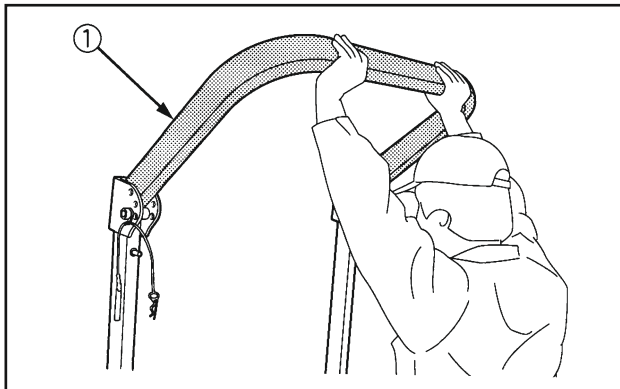

1. ROPS

- After folding insert both set bolts and secure them with the nuts.

⚠ CAUTION

To avoid personal injury:

- Make sure that both set bolts are properly installed and secured with the nuts.

2.2.3. TO RAISE THE ROPS TO UPRIGHT POSITION

1. Remove the both ROPS mounting pins .

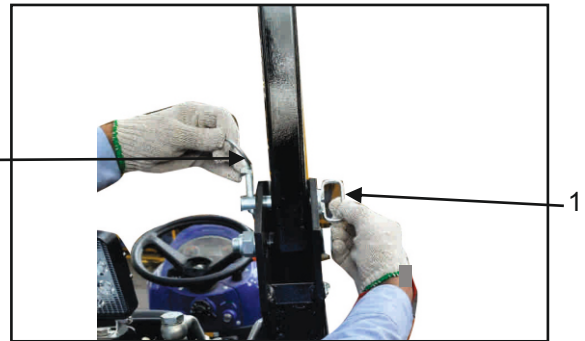

1. ROPS Mounting Pins 2. Lynch Pin

- Raise ROPS to the upright position, maintain a hold on the ROPS.

⚠ CAUTION

To avoid personal injury: Raise the ROPS slowly and carefully.

2.2.4 ADJUSTMENT OF FOLDABLE ROPS

- Adjust free fall of the ROPS upper frame regularly.
- If you feel less friction in folding the ROPS, tighten the nut (1) until you feel the right friction in the movement.

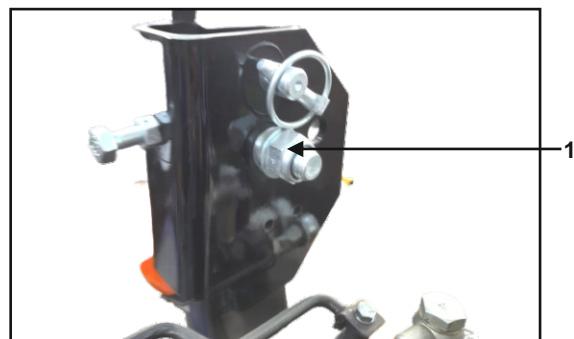

1. Nuts.

2.3 SAFETY FEATURES

1. MSD switch -To Cut off the 73 Volt output from Battery Box. MSD Switch (1) is in "ON" position rotate the switch in anti clockwise direction to cut "OFF" the battery supply.

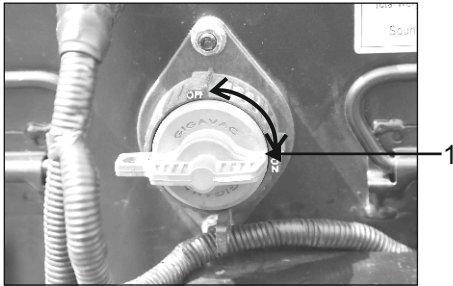

1. MSD Switch

2. Charging Interlock –If the charger is plugged on Vehicle, tractor will not work(controller will not give supply to motor)



1. RCD Cable

3. Safety Interlock – Tractor will not run if the throttle is not zero before start. FNR switch is in neutral 'N' mode.
4. Seat OPS –If driver gets down without engaging the parking brake, tractor system will automatically shut Off within 7 Sec.
5. We careful while handling orange color cables. All orange cable are high voltage.

2.4 SAFETY FOR CHILDREN

Tragedy can occur if the operator is not alert to the presence of children. Children generally are attracted to machines.

1. Never assume that children will remain where you last saw them.
2. Keep children out of the work area and under the watchful eye of another responsible adult.
3. Be alert and shut your machine down if children enter the work area.
4. Never carry children on your machine. Machine is not safe place for children to ride. They may fall off and be run over while running machine.
5. Never allow children to operate the machine even under adult supervision.
6. Never allow children to play with the machine or the implement.
7. Use extra caution while reversing the tractor. Look behind and down to make sure area is clear before moving.

2.5. OPERATING ON SLOPES

Slopes are a major factor related to loss-of-control and tipover accidents, which can result in severe injury or death. All slopes require extra caution.

1. To avoid upsets, always back up steep slopes. If you cannot back up the slope or if you feel uneasy on it, do not operate on it. Stay off slopes too steep for safe operation.
2. Driving forward out of a ditch, mired condition or up a steep slope increases the risk of a tractor to be upset backward. Always back out of these situations. Extra caution is required with 4-wheel drive models because their increased traction can give the operator false confidence in the tractor's ability to climb slopes.
3. Keep all movement on slopes slow and gradual. Do not make sudden changes in speed, direction or apply brake and make sudden motions of the steering wheel.
4. Special attention should be made to the weight and location of implements and loads as such will affect the stability of the tractor.
5. To improve stability on slope, set widest wheel track width as shown in "TYRES, WHEELS AND BALLAST" section. Follow recommendations for proper ballasting.

2.6 DRIVING THE TRACTOR ON THE ROAD

1. Lock the 2 brake pedals together to help assure straight-line stops. Uneven braking at road speeds could cause the tractor to tip over.

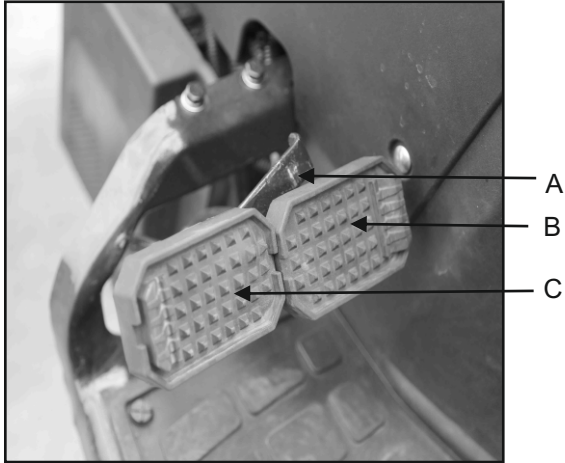

(A) Brake Pedal Lock (B) Brake Pedal (RH)
(C) Brake Pedal (LH)

2. Check the front wheel engagement. The braking characteristics are different between 2 and 4-wheel drive. Be aware of the difference and use carefully.
3. Always slow the tractor down before turning. Turning at high speed may over turn tractor.
4. Make sure that the Slow Moving Vehicle (SMV) sign is clean and visible. Use hazard lights and turn signals as required.

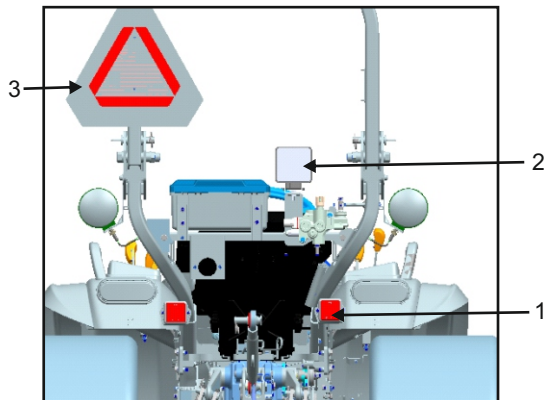

1. Rear Reflection 2. Plough Light
3. Slow Moving Vehicle Emblem

5. Observe all local traffic and safety regulations.
6. Turn the headlights on when sun light is insufficient.
7. Drive at speeds that allow you to maintain control at all times.
8. Do not apply the differential lock while traveling at road speeds. The tractor may run out of control.
9. Avoid sudden motions of the steering wheel as they can lead to a dangerous loss of stability. The risk is especially great when the tractor is traveling at road speeds.

2.7 USING 3-POINT HITCH

1. Use the 3-point hitch only with equipment designed for 3-point hitch usage.
2. When using a 3-point hitch mounted implement, be sure to install the proper counterbalance weight on the front of the tractor.
3. When transporting on the road, set the "TRANSPORT LOCK KNOB" in the lock position to hold the implement in the raised position.

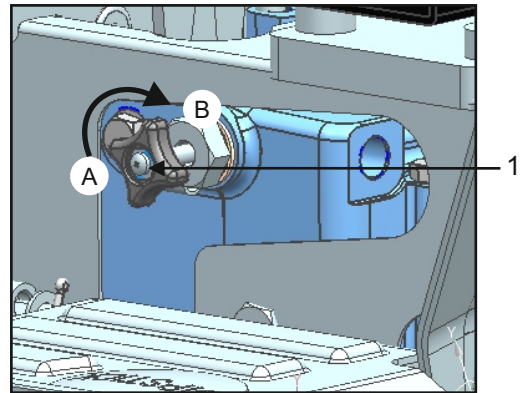

(1) Transport Lock Knob
(A) "OPEN" (B) "LOCK"

2.8 DAILY CHECK

To prevent trouble from occurring, it is important to know the condition of the tractor well. Check it before starting.

Check item

- Walk around inspection
- Check transmission oil level
- Check brake pedal
- Check indicators, gauges and meter
- Check lights
- Check wire harness
- Check Seat belt and ROPS

-Auxiliary spool valve lever should be in neutral position

- Check movable parts
(See "DAILY CHECK" in "PERIODIC SERVICE" section.)

- Care of danger, warning and caution labels (See "DANGER, WARNING AND CAUTION LABELS" in "SAFE OPERATION" section.) PRE-OPERATION

- Check before each use that operator presence controls are functioning correctly. Test safety systems.
(See "Checking Tractor Start System" in "EVERY 50 HOURS" in "PERIODIC SERVICE" section.) Do not operate unless they are functioning correctly.

2.9 GENERAL WORKING INSTRUCTIONS

1. Pull only with the swinging drawbar. Never hitch to axle housing or any other point except swinging drawbar; such arrangements will increase the risk of serious personal injury or death due to a tractor instability

2.9.1 BOARDING AND LEAVING THE TRACTOR

1. Never try to get on or off a moving tractor or jump off the tractor to exit.
2. Face the tractor when getting into or out of the tractor. Do not use the controls as hand holds to prevent inadvertent machine movements.
3. Always keep steps and floor clean to avoid slippery conditions.

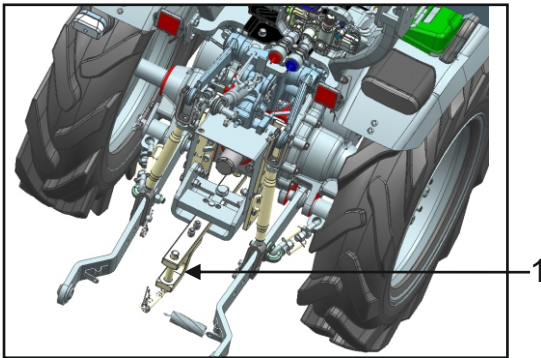

(1) Swinging Drawbar

4. For trailing PTO-driven implements, set the swinging drawbar to the towing position.
5. Attach pulled or towed loads to the swinging drawbar only.
6. Keep all shields and guards in place. Replace if anything is missing or damaged.
7. Avoid sudden starts. To avoid instability, slow down when turning, on uneven ground, and before stopping.
8. The tractor cannot turn with the differential locked and attempting to do so could be dangerous.
9. Do not operate near ditches, holes, embankments, or with other ground surfaces which may collapse under the tractor's weight. The risk of tractor instability is even higher when the ground is loose or wet. Tall grass can hide obstacles, walk the area first to be sure.
10. Watch where you are going at all times. Watch for and avoid obstacles. Be alert at row ends, near trees, and other obstructions.
11. When working in groups, always let the others know what you are going to do before you do it.
12. Never try to get on or off a moving tractor.
13. Always sit in the operator's seat when operating levers or controls.
14. Do not stand between tractor and implement or trailed vehicle unless parking brake is applied.

⚠ WARNING

To avoid personal injury or death:

- Be sure to check and service the tractor on a level surface with the tractor shut off and the parking brake "ON" and implement lowered to the ground

15. Keep the ROPS in the "UP" position and wear the seat belt when driving the tractor on the road. Otherwise, you will not be protected in the event of a tractor roll-over.
16. Do not operate an implement while the tractor is on the road. Lock the 3-point hitch in the raised position.
17. When towing other equipment, use a safety chain and place an SMV emblem on it as well.

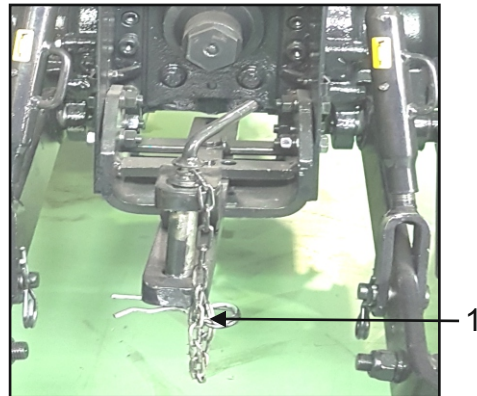

(1) Safety Chain

18. Use extreme caution and avoid hard application of the tractor brakes when towing heavy loads. Any towed vehicle whose total weight exceeds that of the tractor must be equipped with brakes for safe operation.
19. Always check overhead clearance, especially when working in confined spaces.

2.10 WASHING INSTRUCTIONS

1. Switch Off the Tractor from Starting Key.
2. Turn Off MSD Switch.
3. Charging socket cap should be in closed conditions while washing the tractor.
4. 12V battery cut off switch should be in off conditions.
5. Maintain distance at list one meter if you are using high pressure water.
6. Do not Start Tractor for 15 Minutes after washing.
7. Avoid Direct jet of water on high voltage (Orange color) wires as shown in figure below.
8. Do not charge the tractor instantly after washing. Wait for 30 mints then charge the tractor.



1. High Voltage Cable

2.11 PARKING THE TRACTOR

1. Disengage the PTO, lower all implements to the ground, place all control levers in their neutral positions, set the parking brake, stop the tractor, remove the key from the ignition. Leaving transmission in gear with the tractor stopped will not prevent tractor from rolling.
2. Make sure that the tractor has come to a complete stop before dismounting.
3. Avoid parking on steep slopes, if at all possible park on a firm and level surface; if not, park across a slope with Choke the wheels. Failure to comply with this warning may allow the tractor to move and could cause injury or death.
4. Apply trailer parking brake while parking the tractor on slope.

2.12 CARE OF DANGER, WARNING AND CAUTION LABELS

1. Keep danger, warning and caution labels clean and free from obstructing material.
2. Clean danger, warning and caution labels with soap and water, dry with a soft cloth.
3. Replace damaged or missing danger, warning and caution labels with new labels from your local FARMTRAC Dealer / Distributor

4. If a component with danger, warning and caution labels affixed is replaced with new part, make sure new labels are attached in the same locations as the replaced component.
5. Mount new danger, warning and caution labels by applying on a clean dry surface and pressing any bubbles to outside edge.

Overhead Power lines :

1. Due to less gap between Earth and power line, do not cross the tractor on that place. Accident can be happened.

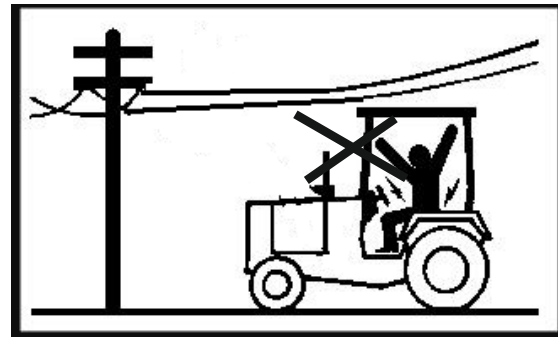

Lighting strikes can cause significant injury or death

Action : Move indoors if you hear thunder

- Severe thunderstorm Warning means Take Action
- Take shelter indoors immediately
- Use extra caution while driving
- Check forecast updates stay weather ready

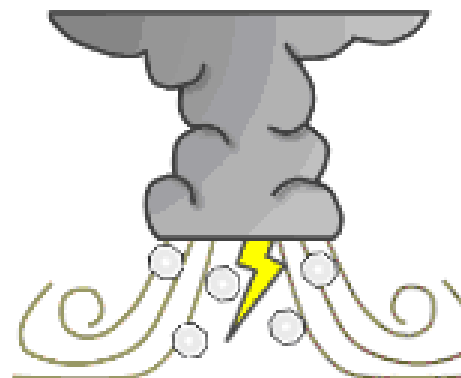

CHAPTER -3. SAFE NOTES

D10616510

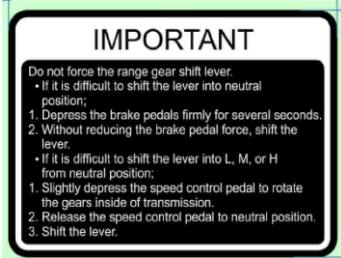

D10616570

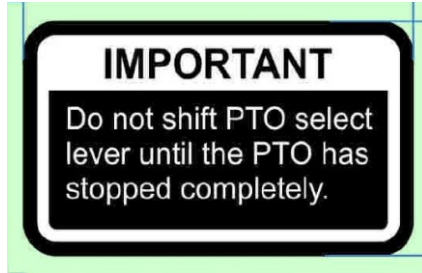

D10570020

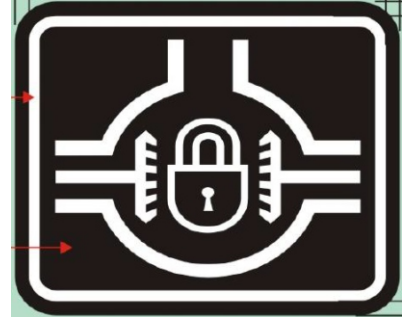

D10570030



D10570050



D10647910

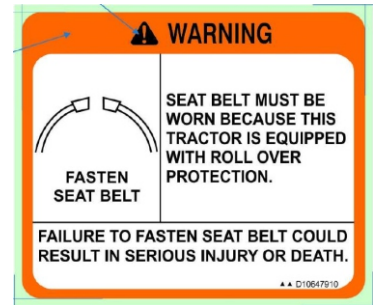

D10570030



D10588450

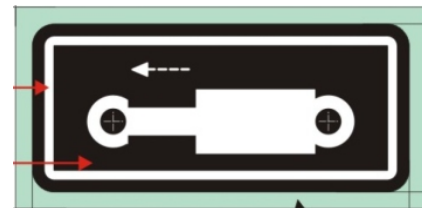

D10570830



D10588440

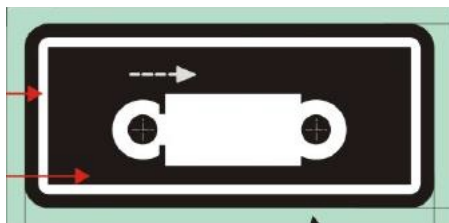

D10647840



D10570780



D10570340



D10570900

FARMTRAC

INSTRUCTIONS FOR USING LIFT

- Bring both levers (Red draft and black position) towards down position.
- Take red lever (Up Position) till lift starts raising. Then bring it to slightly down position.
- Run the tractor in correct ploughing gear and speed.
- While tractor is ploughing, bring red lever down very slowly, until you get the right depth (without overload) and then lock the lever with the knob.
- As required use black lever for using lift up and down.

D10647880

⚠ DANGER

START ONLY FROM SEAT WITH TRANSMISSION AND PTO IN NEUTRAL.
STARTING IN GEAR KILLS

▲▲ D10647880

D10647900

⚠ WARNING

WHENEVER CLEARANCE PERMITS :-
KEEP ROLL OVER PROTECTION FULLY EXTENDED AND LOCKED.
KEEP SEAT BELT FASTENED
WHEN STRUCTURE MUST BE LOWERED
DRIVE WITH EXTRA CARE
SEAT BELT USE IS NOT RECOMMENDED
NO ROPS PROTECTION IS PROVIDED IN LOWERED POSITION.

▲▲ D10647900

D10570330



D10817660



D10817670

POWER STORAGE

REGENERATE

REGENERATIVE BRAKING

POWER SUPPLY

● D10817670A

D10817680

HYDRAULIC PUMP must be in 'ON' position while Tractor is Moving

●● D10817680A

D10817690

LIFT selection switch must be in 'ON' position while using Lifting operations

●● D10817690A

D10817700

⚠ WARNING DO NOT OPEN THE HOOD WHILE CHARGER IS PLUGGED IN

●● D10817700A

D10858690

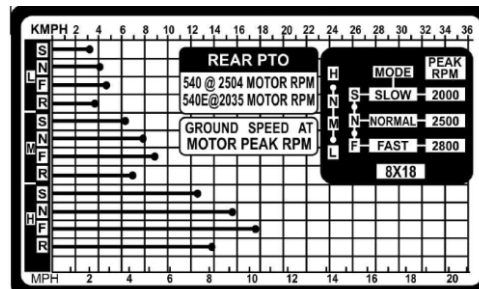

D11043230



D11043250

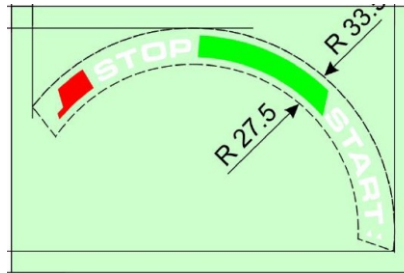

D10820340

SAFETY INSTRUCTIONS

- IT IS ESSENTIAL TO READ THE MANUAL CAREFULLY. OPERATOR MUST BE WELL FAMILIAR WITH ALL CONTROLS, AND WHEN REQUIRED, PROPERLY LICENSED.
- DO NOT DISMANTLE OR ASSEMBLE FROM THE TRACTOR WHILE IT IS IN MOTION EXCEPT IN AN EMERGENCY.
- DO NOT STAND IN-BETWEEN THE TRACTOR AND EQUIPMENT WHEN OPERATING CONTROLS.
- KEEP CLOTHING, HANDS AND FEET AWAY FROM MOVING PARTS.
- DO NOT MAKE ANY ADJUSTMENT WHEN TRACTOR IS IN OPERATION.
- WEAR ADEQUATE FOOTWEAR AND SNUG-FITTING CLOTHING.
- DO NOT SIT OR STAND ON UNSAFE PLACE WHEN TRACTOR IS MOVING.
- KEEP DISPLAY BOARDS, HANDLES AND DRIVER'S POSITION CLEAN.
- KEEP ALL SAFETY GUARDS IN PLACE WHILE WORKING.
- MAKE SURE THAT NO TRAINS ARE COMING BEFORE CROSSING THE UNGUARDED RAILWAY CROSSING.

FARMTRAC • • D10820340A

4.1 TRACTOR OVERVIEW

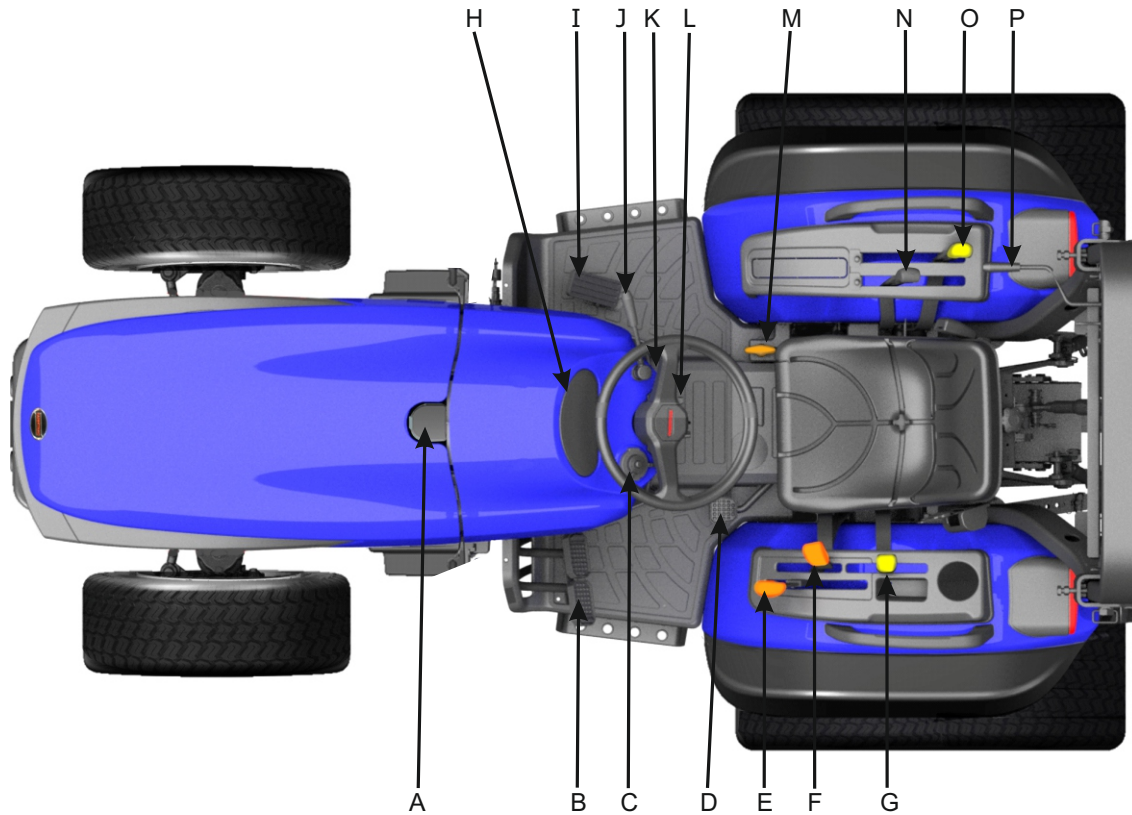

A	Charging Port
B	Brake Pedals
C	Combination Switch (lights, Indicators & Horn)
D	Differential Lock Pedal
E	Range Lever (High, Neutral, Medium, Low)
F	2WD/4WD Lever
G	Rear PTO Lever
H	Instrument Cluster
I	Foot Throttle
J	Hand Throttle
K	SNF (Slow, Normal, Fast) & F/R Switch
L	Switch Panel
M	Parking Brake
N	Draft Control Lever
O	Position Control Lever
P	Auxiliary Valve Lever

4.2 INSTRUMENT CLUSTER & FUNCTIONS.

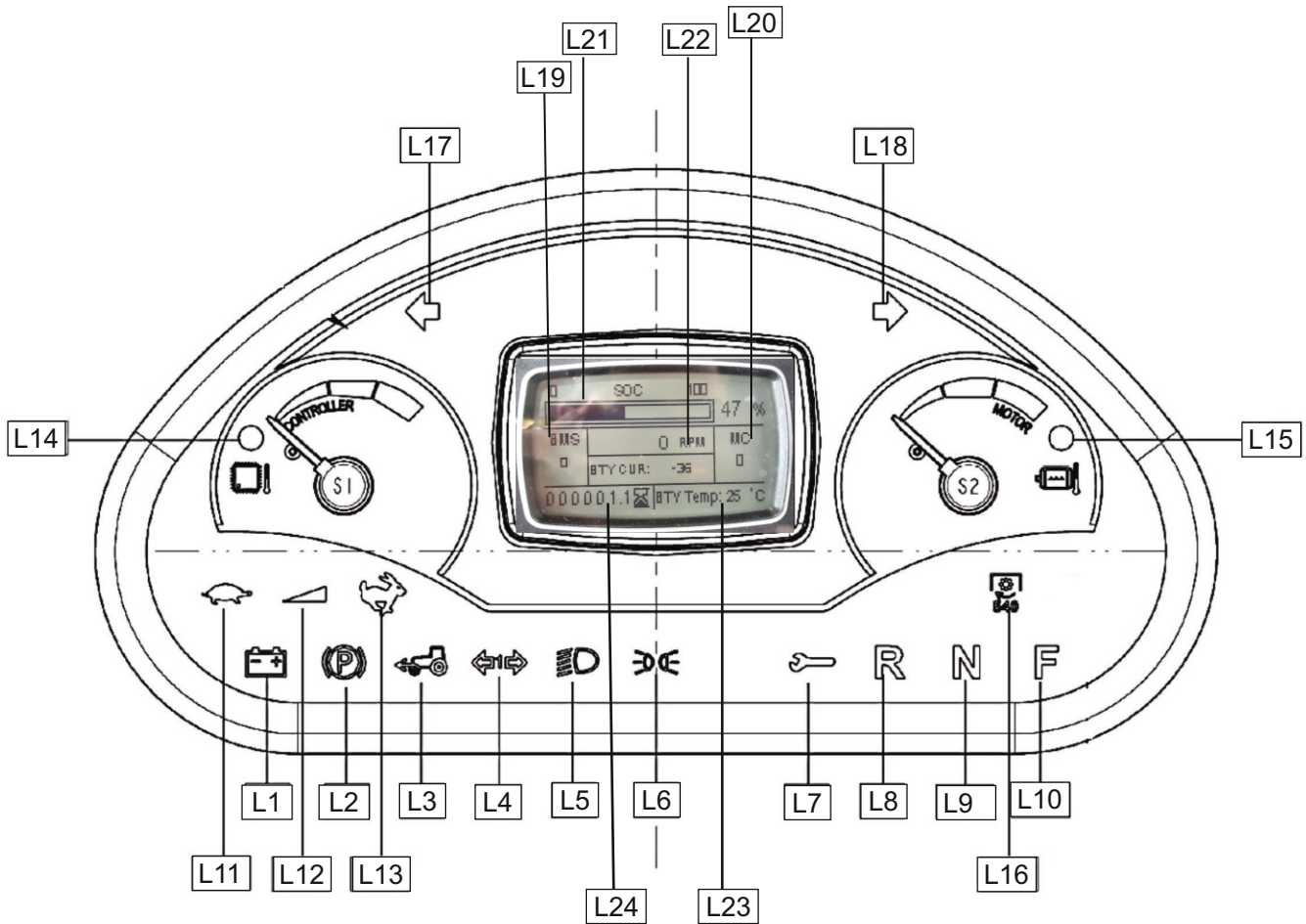

L1	Battery Charging	L14	Controller Temperature
L2	Parking Brake	L15	Motor Temperature
L3	4WD Engaged	L16	Rear PTO
L4	Turn Trailer	L17	Left Indicator
L5	Projector Lamp	L18	Right Indicator
L6	Position Lamp	L19	BMS Error
L7	Malfunction	L20	Motor Controller Error Code
L8	Reverse	L21	Battery State of Charge (SOC)
L9	Neutral	L22	Motor RPM
L10	Forward	L23	Battery Temperature
L11	Low Throttle	L24	HMR
L12	Throttle Low/Hi		
L13	High Throttle		

4.2.1 WARNING SYMBOLS & INDICATION ON INSTRUMENT CLUSTER

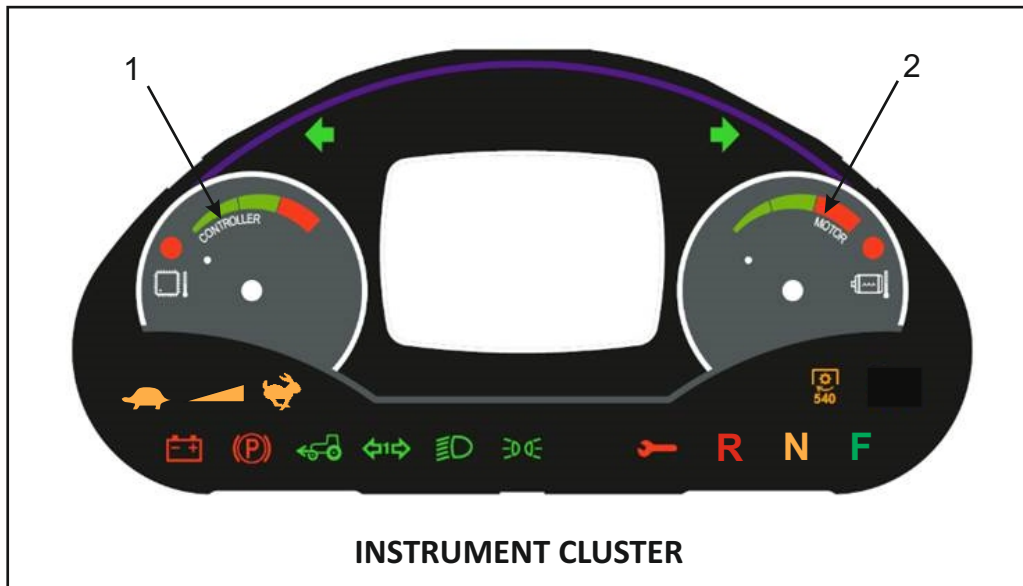

1. MAIN CONTROLLER TEMPERATURE
2. MOTOR TEMPERATURE

Function Name	Color	Symbol (Attach Symbol)	Function Name	Color	Symbol (Attach Symbol)
Battery Charging	Red		Controller Temp. High	Red	
Parking Brake apply	Red		Motor Temp. High	Red	
4 WD	Green		Fast Mode	Amber	
Turn Trailer	Green		Normal	Amber	
Dipped Beam Green	Green		Slow Mode	Amber	
Position Lamp	Green		Left Direction	Green	
Service	Red		Right Direction	Green	
Reverse	Red	R	PTO 540	Amber	
Neutral	Amber	N			
Forward	Green	F			

4.2.2 DIGITAL PANEL

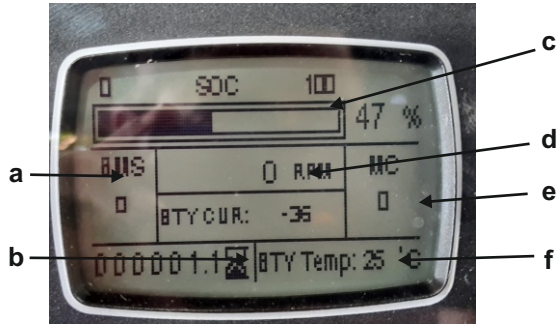

- a. BMS Error Code Display
- b. Hour Meter
- c. Soc Bar
- d. Motor RPM
- e. Motor controller error code.
- f. Battery Temperature

a. BMS Error Code Display

Its indicates BMS error code.

⚠ Warning : If error code appears on cluster, look for the problem according to the error code chart and go for service assistance at farmtrac dealership.

b. Hour Meter

It records hours the tractor has run.

c. Soc Bar (State of charge)

SOC or battery charge indication will be shown on the display in the form of a BAR from 0 to 100%.

⚠ Warning : Use the battery from full charge of 100 percent to 20 percent before recharging so that no of charging cycles can be kept to minimum.

d. Motor RPM

It records RPM the tractor has run.

e. Motor controller error code.

Its indicates motor controller error code.

f. Battery Temperature

Its indicates main battery temperature

NOTE :

- Recommended operating temperature (Discharging) : $-10^{\circ}\text{C} \sim 55^{\circ}\text{C}$
- Recommended operating temperature (Charging) : $0^{\circ}\text{C} \sim 55^{\circ}$

4.3 MALFUNCTION TELL TAIL ON CLUSTER.

If Warning tell tail glows on cluster and remains on even after switching on the tractor, contact your dealer for assistance and repair.



⚠ Warning Do not operate tractor if either of motor or controller temperature is in red region of the gauges.

4.4 DASHBOARD

FNR (Forward, Neutral, Reverse) switchin combination with SNF (Slow, Normal, Fast) range switch: Below are the following functions.

4.4.1 FNR Switch—It is used to select Forward/Reverse direction.

4.4.2 SNF Range Switch—It is used to select the motor max RPM range.
(S -< 2000RPM, N -< 2500 RPM, F -< 2800 RPM)

In Reverse mode, the motor rpm is less than 2240 RPM which is independent of SNF switch.

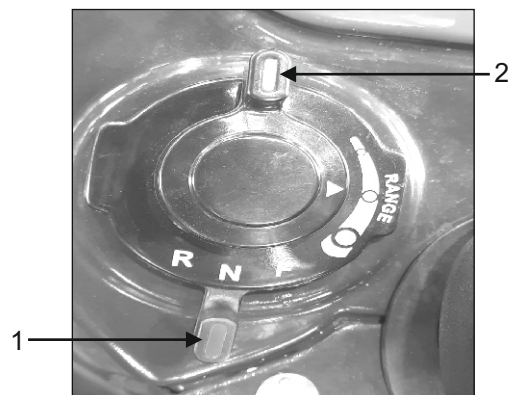

- 1. FNR Switch
- 2. SNF Range Switch

4.5 DASHBOARD SWITCHES FUNCTIONS .



1. Lift Mode Selection Switch
2. Pump ON/OFF switch
3. PTO Wet Clutch Switch
4. Hazard Switch

4.5.1 Lift Mode Selection Switch- when the switch is at OFF position, motor runs on low RPM to use power steering. When the switch is at ON position, motor runs on higher rpm to use lift operation.

4.5.2 Pump ON/OFF Switch- It starts motor coupled with 5.5cc gear pump to start the hydraulic motor.

4.5.3 PTO Wet Clutch Switch : Press the switch to engage the PTO.

4.5.4 Hazard Switch : Press the switch to operate the hazard lights.

NOTE : When pump on/off switch is at off position the steering operates manually. Do not turn pump on/off switch at off position while traveling on road.

⚠ Warning : When the steering wheel is turned all the way to the stop, the relief valve is activated. Do not hold the steering wheel in this position for a long period of time.

Avoid turning the steering wheel while the tractor is stopped, or tyres may wear out sooner.

The power steering mechanism makes the steering easier. Be careful when driving on a road at high speeds.



- A. Key Start Switch
- B. Mobile charging Socket

4.5.5 Combination Switch –It is used for left and right Indicators, horn and head light switch. Turn the red switch into left and right direction to switch on the left and right indicators. Turn the yellow switch to operate signature lamp, low and high beam of head light.

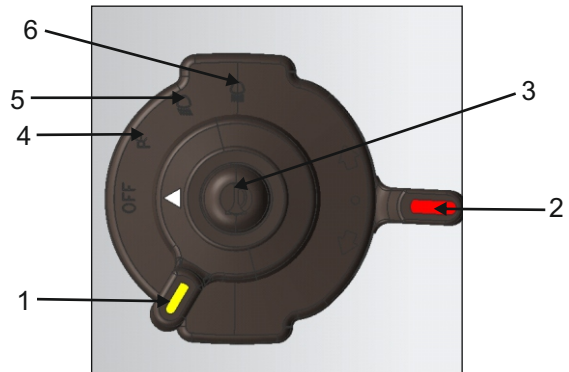

1. Light Switch
2. Turn Signal Switch
3. Horn
4. Signature Lamp
5. Low Beam
6. High Beam



4. Signature Lamp

CHAPTER 5 - OPERATING THE TRACTOR

5.1 PRE CHECKS BEFORE STARTING THE TRACTOR

Operator safety is a priority. Safe operation, specifically with respect to overturning hazards, requires understanding the equipment and environmental conditions at the time of use. Some prohibited uses which can affect overturning hazards include traveling and turning with implements and loads carried too high etc. It is the operator's responsibility to be alert for any equipment or environmental condition that could compromise safe operation.

- Sit on the tractor.

- Sit on the tractor.

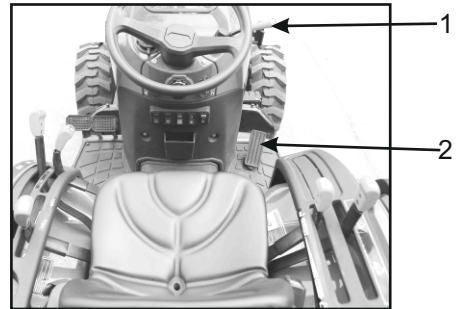

1. Hand throttle
2. Foot Throttle

- Check for both the throttles are on zero position.
- FNR switch should be in Neutral.
- Parking brake should be disengaged.



1. MSD Switch

- Switch on auxiliary battery cut off switch.

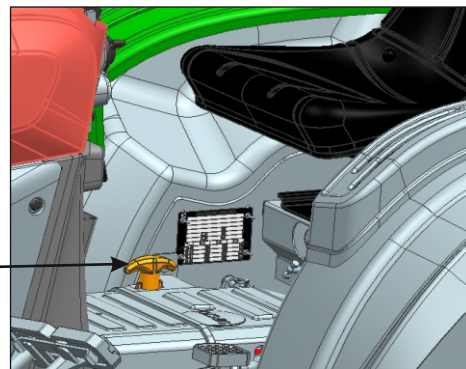

1. Parking Brake

- Pump on /off switch should be in "OFF" Position .

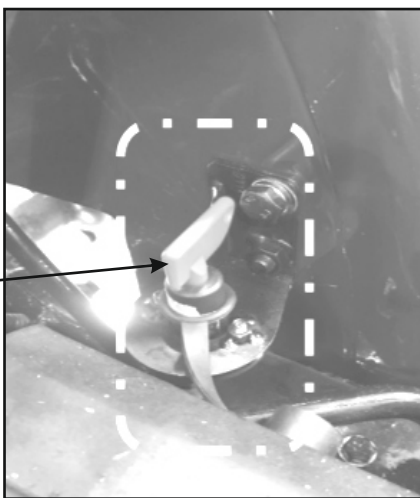

1. Battery Cut Off Switch



1. Pump ON / OFF Switch

- HLM Range lever should be in Neutral.

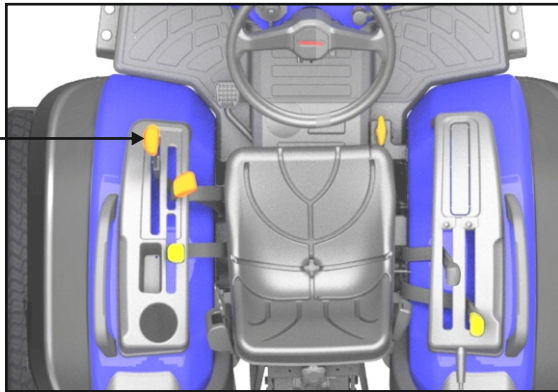

1. Range lever

- SNF switch can be used in any position, anytime (Condition: if we change from S to N on the same throttle RPM, the RPM will rise wrt. previous mode).

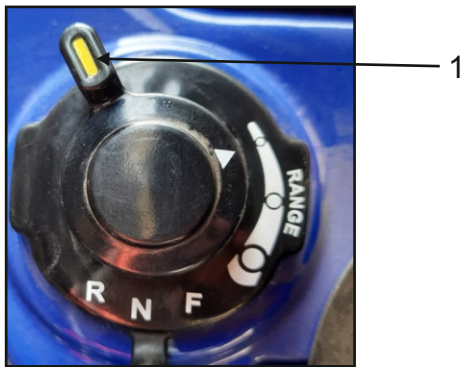

1. SNF Switch

⚠ WARNING

To avoid personal injury or death :

- Read "Safe Operation" in the front of this manual.
- Read this danger, warning and caution labels located on this tractor.
- Never start tractor while standing on ground. Start tractor only from operator's seat.
- Make it a rule to set all shift levers to the "NEUTRAL" positions and to place the PTO lever in "OFF" position.

IMPORTANT:

NOTE: It is recommended that the operator practice engaging and disengaging the parking brake on a flat surface without the motor running before operating the tractor for the first time.

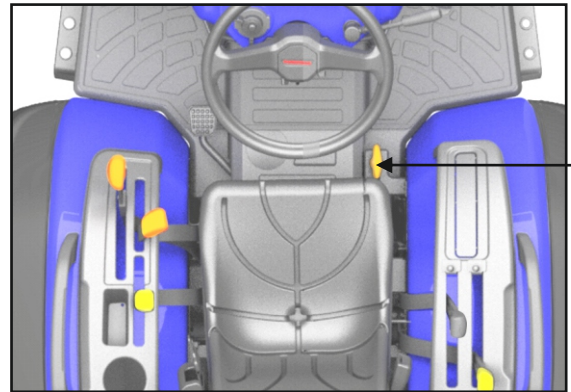

1. Parking Brake Lever

5.2 SELECTING THE TRAVEL SPEED.

- **Range Gear Shift Lever (L-M-N-H)**

The range shift lever can only be shifted. It is placed on the left hand side of the tractor.

IMPORTANT:

- Do not force the range gear shift lever.
- Shift the range gear lever according to speed and load of the tractor.
- To avoid damage of transmission, stop tractor before shifting between ranges.
- To shift the range gear lever. Press brake pedal (without disturbing setting of hand throttle). Motor RPM will come to zero, shift the lever (keep brake pedal pressed) as per requirement. Release the brake pedal, tractor will start running.

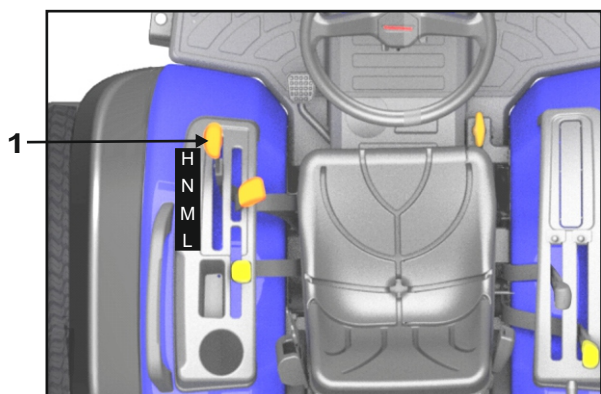

(1) RANGE GEAR SHIFT LEVER (L-M-N-H)
 (L) "LOW"
 (M) "MEDIUM"
 (N) "NEUTRAL POSITION"
 (H) "HIGH"

⚠ WARNING

Avoid Damage!

To prevent transmission damage, stop machine motion completely before shifting the range shift lever.

To avoid overheating do not use the tractor beyond recommended load capacity

If the tractor is not moving with recommended load, stop the tractor and report to concern person. Do not force the range gear shift lever.

If it is difficult to shift the range gear shift lever into the neutral position;

- (1) Depress the brake pedal firmly for several seconds.
- (2) Without reducing the brake pedal force, shift the range gear shift lever.

If it is difficult to shift the range gear shift lever into "L", "M" or "H" from neutral position;

- (1) Slightly depress the speed control pedal for movement.
- (2) Release the speed control pedal to neutral position.
- (3) Press the brake pedal & shift the range gear shift lever.

5.3 ADJUSTING THE OPERATOR'S POSITION.

NOTE:

- The seat and suspension should be adjusted to ensure that the controls are comfortably at hand for the operator, ensuring that the operator maintains a good posture and minimizes risks from whole body vibration.

Operator's Seat

⚠ WARNING

To avoid personal injury or death:

- Make sure that the seat is completely secured after each adjustment.
- Do not allow any person other than the driver to ride on the tractor.

◆ Position Adjustment Lever

Pull in the position adjust lever (2) and slide the seat backward or forward, as required. The seat will lock in position when the lever is released.

◆ Height Adjustment Knob

To adjust the height of the seat, loosen the two height adjustment knobs (3) on both sides of the seat frame. Set the seat to desired height manually and tighten the knobs.

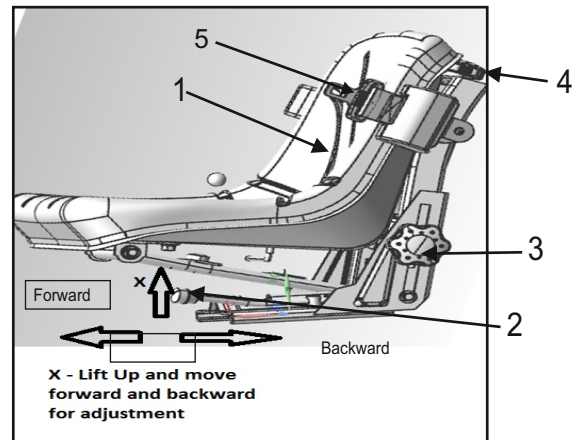

E-Marked Seat

1. Seat
2. Position Adjust Lever
3. Height Adjustment Knob
4. Weight Adjustment Knob
5. Seat Belt

◆ Weight Adjustment Knob

To achieve the optimum suspension setting sit on the seat and turn the weight adjustment knob (4) as per weight indication mention behind the operator seat.

NOTE : Weight adjustment can be adjust from 51kg to 130kg.

IMPORTANT:

- After adjusting the operator's seat, be sure to check that the seat is properly locked.

◆ Seat Belt

⚠ WARNING

To avoid personal injury or death:

- Always use the seat belt when the ROPS is installed.
- Do not use the seat belt if a foldable ROPS is down or there is no ROPS.

Adjust the seat belt for proper fit and connect to the buckle. The seat belt is auto-locking retractable type.

5.4 Operator presence switch : When the operator leaves the driving seat, the vehicle will shut off automatically within 7-10 sec.

NOTE : Operator presence switch is available.

5.5 SELECTING LIGHT SWITCH POSITIONS.

• Head Light | Turn Signal / Hazard Light Switch

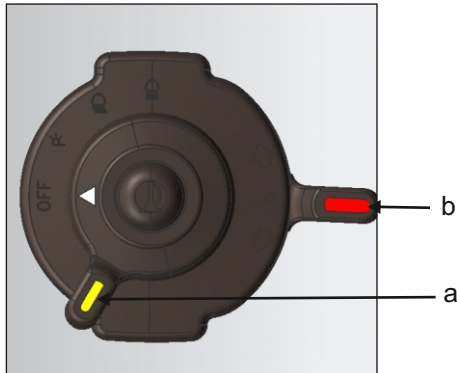

a. Head Light Switch
b. Turn Signal Switch

◆ **Head Light Switch** :- Hazard light switch has three positions.

- 1st Head light "OFF"
- 2nd Position lamp.
- 3rd Dipped beam.

◆ Hazard Light

1. When hazard light switch is pressed, the hazard lights flash, along with the L/H and R/H indicators on the instrument panel.
2. Push hazard light switch again to turn off the hazard lights.

◆ Turn Signal with Hazard Light Switch On

1. To indicate a right turn with the hazard lights already flashing (hazard switch on), turn the turn signal switch clockwise.
2. To indicate a left turn with the hazard lights already flashing, turn the turn signal switch counterclockwise.
3. When the left or right turn signal is activated in combination with the hazard lights, the indicated turning light will flash and the other will stay on.

◆ Turn Signal with Hazard Light Switch Off

1. To indicate a right turn without hazard lights (hazard switch off), turn the turn signal switch clockwise.
2. To indicate a left turn without hazard lights, turn the turn signal switch counterclockwise.
3. When the left or right turn signal is activated without the hazard lights, the indicated turning light will flash and the other will stay on.

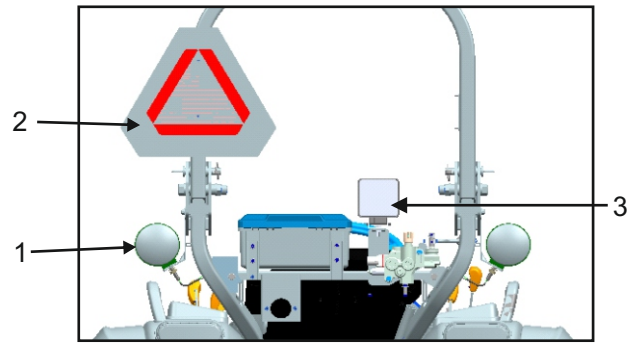

1. Hazard Light 2. SMV Emblem
3. Plough Lamp

◆ **Plough Lamp** :- It is present on rear end of tractor. It is provided with a push button. Plough lamp glows irrespective of key start switch is in "ON" or "OFF" position.

5.6 BRAKE PEDALS (RIGHT AND LEFT)

⚠ WARNING

To avoid personal injury or death:

- An accident may occur if the tractor is suddenly braked, such as by heavy towed loads shifting forward or loss of control.

- When driving on icy, wet or loose surfaces, make sure the tractor is correctly ballasted to avoid skidding and loss of steering control. Operate at reduced speed.

1. Before operating the tractor on the road or before applying the parking brake, be sure to interlock the right and left pedals as illustrated below.
2. Use individual brakes to assist in making sharp turns at slow speeds (Field Operation Only). Disengage the brake pedal lock and depress only one brake pedal.
3. Be sure brake pedals have equal adjustment when using locked together.

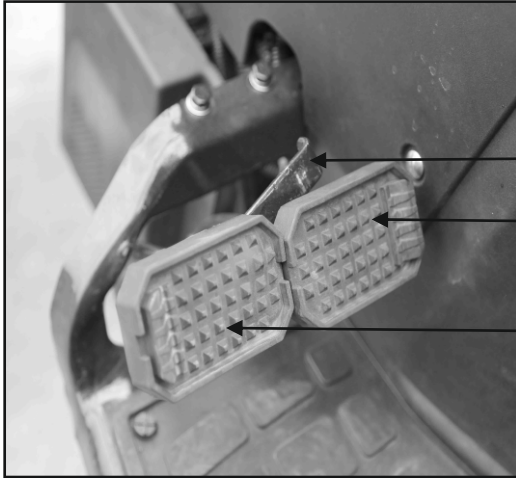

**A. Brake Pedal Lock, B. Right Brake Pedal
C. Left Brake Pedal**

5.7 FOUR WHEEL DRIVE LEVER (4WD)

⚠ WARNING

To avoid personal injury or death:

- Do not engage the four wheel drive when traveling at road speed.
- When driving on icy, wet or loose surfaces, make sure the tractor is correctly ballasted to avoid skidding and loss of steering control. Operate at reduced speed and engage four wheel drive.
- An accident may occur if the tractor is suddenly braked, such as by heavy towed loads shifting forward or loss of control.
- The braking characteristics are different between 2 wheel and 4-wheel drive. Be aware of the difference and use carefully.

Use the lever to engage the four wheels with the tractor stopped. Move the lever in forward and backward direction to disengage and engage the four wheel drive.

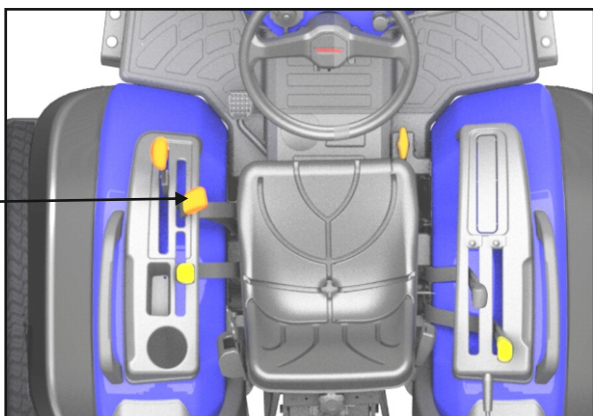

1. Four Wheel Drive Lever

IMPORTANT:

- To avoid damage of transmission, when four wheel drive lever is not smoothly shifted, slightly step forward or reverse.
- Tyres will wear quickly if four wheel drive is engaged on paved roads.

◆ Four wheel drive is effective for the following jobs:

1. When greater pulling force is needed, such as working in a wet field, when pulling a trailer, or when working with a front-end loader.
2. When working in sandy soil.
3. When working on a hard soil where a rotary tiller might push the tractor forward.
4. Additional braking at reduced speeds.

5.8 HAND THROTTLE LEVER

Pulling the throttle lever back increases motor speed, and pushing it forward decreases motor speed.

NOTE : Always keep & hand throttle in position (A) before starting the tractor otherwise tractor will not start



**(1) Hand Throttle lever if
(B) INCREASE" (A) DECREASE"**

5.9 DIFFERENTIAL LOCK

⚠ WARNING

To avoid personal injury or death due to loss of steering control:

- Do not operate the tractor at high speed with differential lock engaged.
- Do not attempt to turn with the differential lock engaged.
- Be sure to release the differential lock before making a turn in field conditions.

If one of the rear wheels slip, step on the differential lock pedal. Both wheels will turn together, then reduce slippage.

Differential lock is maintained only while the pedal is depressed.

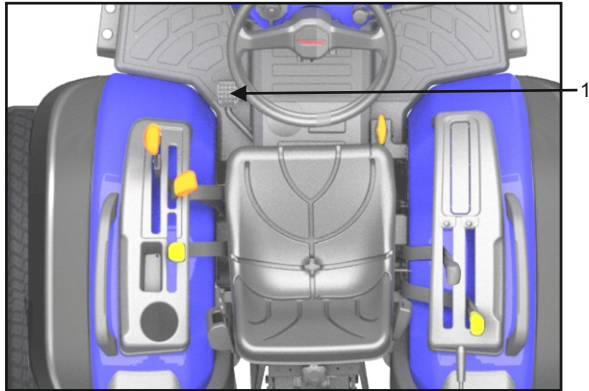

1. Differential Lock Pedal

IMPORTANT:

- When using the differential lock, always slow the tractor down.
- To prevent damage to power train, do not engage differential lock when one wheel is spinning and the other is completely stopped.
- If the differential lock cannot be released in the above manner, step lightly on the brake pedals alternately.

5.10 OPERATING ON SLOPES OR ROUGH TERRAIN

⚠ WARNING

To avoid personal Injury or death:

- Always back up when going up a steep slope. Driving forward could cause the tractor to tip over backward. Stay off hills and slopes too steep for safe operation.
- Avoid changing gears when climbing or descending a slope.
- If operating on a slope, never disengage shift levers to neutral. Doing so could cause loss of control.
- Do not drive the tractor close to the edges of ditches or banks which may collapse under the weight of the tractor. Especially when the ground is loose or wet.

1. Slow down for slopes, rough ground, and sharp turns, especially when transporting heavy, rear mounted equipment.
2. Before descending a slope, be sure that the range lever is in the low so that speed can be controlled without using brakes.

5.11 TRANSPORT THE TRACTOR SAFELY

1. The tractor, if damaged, must be carried on a truck. Secure the tractor tightly with ropes.
2. Follow the instruction below when towing the tractor: Otherwise, the tractor's power train may get damaged.
3. Set the all shift levers to "NEUTRAL" position.
4. Tow the tractor using its front hitch or drawbar.
5. Set the FNR switch to neutral position.

5.12 ELECTRICAL OUTLET

An electrical outlet is used for electrical supply to implement (trailer).



1. 7 Pin Trailer Socket

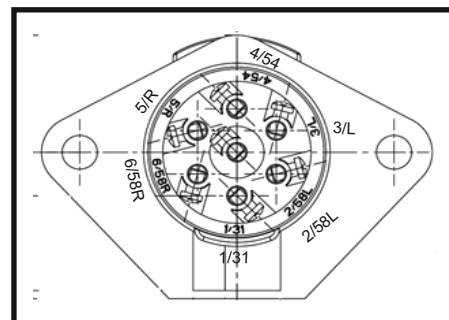

Seven-Terminal Trailer Socket

Conductor Identification terminal num	Color Identification Wire Color	Lamp & Signal Color
Primary		
1	Wht (White)	Ground return to towing vehicle. Clearance, side marker and identification lamp.
2	Bik (Black)	
3	Yel (Yellow)	Left turn signal and hazard lamps stop lamp and antilock braking system (ABS) secondary power)
4	Red (Red)	
5	Grn (Green)	Right turn signal and hazard lamps Tail and license plate clearance and / or side marking lamps
6	Brn (Brown)	
7	Blu (Blue)	Continuous ABS primary power/ auxiliary devices

5.13 PTO

⚠ WARNING

To avoid personal injury or death:

- Before operation, be sure to select the correct PTO mode.

⚠ WARNING

To avoid personal injury or death:

- Disengage PTO, stop tractor, and allow all rotating components to come to a complete stop before connecting, disconnecting, adjusting, or cleaning any PTO driven equipment.

5.13.1 PTO SELECTION LEVER

The tractor has a 540 and 540E rpm rear PTO speed. To obtain 540 RPM set motor RPM to 2504 & for 540E set motor RPM to 2035.

NOTE : 540E used for the tractor lower rpm operation and for lighter loads.

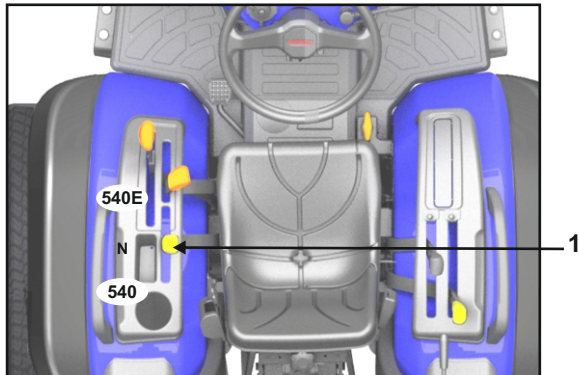

1. PTO Selector Lever

PTO indication switch.

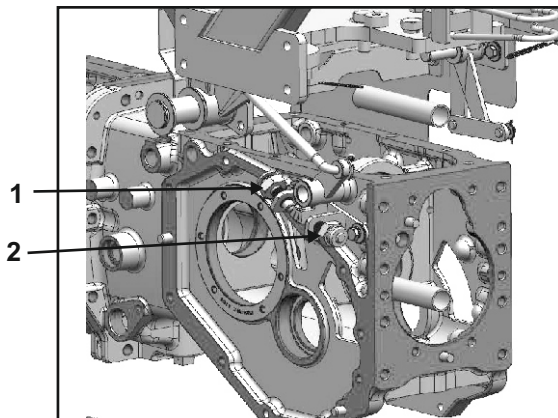

1. PTO Safety Switch 540E
2. PTO Safety Switch 540

NOTE : Before starting the tractor, keep the PTO select lever at the neutral position.

5.13.2 PTO OPERATION.

- Switch on the tractor (All levers should be in neutral condition and throttle in zero position).
- Put the FNR switch in Forward .
- Select SNF (slow, Normal, Fast) mode from mode switch.
- Operate PTO Selection lever.
- Engage the range lever (LMNH)
- Press PTO switch to ON position.
- Set motor rpm to the recommended speed.

5.14 PROCEDURE TO OPERATE TRACTOR-

◆ For Field Applications

- Switch on the ignition (All levers should be in neutral condition)
- Put the FNR switch in Forward .
- Select SNF (slow, Normal, Fast) mode from mode switch.
- Set the RPM with hand throttle
- Press the brakes to bring the motor RPM to zero
- Engage the range lever in high, low or medium
- Release the brakes slowly to start the operation

◆ For Haulage

- Switch on the tractor (All levers should be in neutral condition and throttle in zero position).
- Put the FNR switch in Forward or Reverse.
- Engage the range lever (LMNH)
- Press the foot throttle for desired speed.
- Select SNF mode from mode switch.

◆ Stationary PTO Operation

- Switch off the Ignition.
- Engage the parking brake.
- Get down the tractor.
- Again, switch ON the ignition without sitting on driver seat and wait for 7 second.
- PTO will run after operating PTO selection lever.
- Attach sprayer trailer hitch with tractor by using toe hook pin.
- Attach propeller shaft at tractor PTO shaft by pressing lock given on propeller shaft.
- Attach propeller shaft, sprayer side PTO shaft by pressing lock given on propeller shaft.
- Lift sprayer holding stopper given with sprayer.
- Attach cultivator from right side hitching point by adjusting lift rod if required.
- Attach cultivator from left side hitching point by adjusting lift rod if required.
- Attach cultivator from top side hitching point by adjusting top link if required
- Again switch on the ignition without sitting on seat.
- Put in FNR in forward.
- Switch on the pump(ensure lift mode is off).
- Switch on the wet Clutch(ensure LMNH is neutral)
- Set the RPM with Hand throttle.

Please note:

TPL mounted implements can be attached by using above shown procedure.

5.15 3-POINT HITCH & SWINGING DRAWBAR

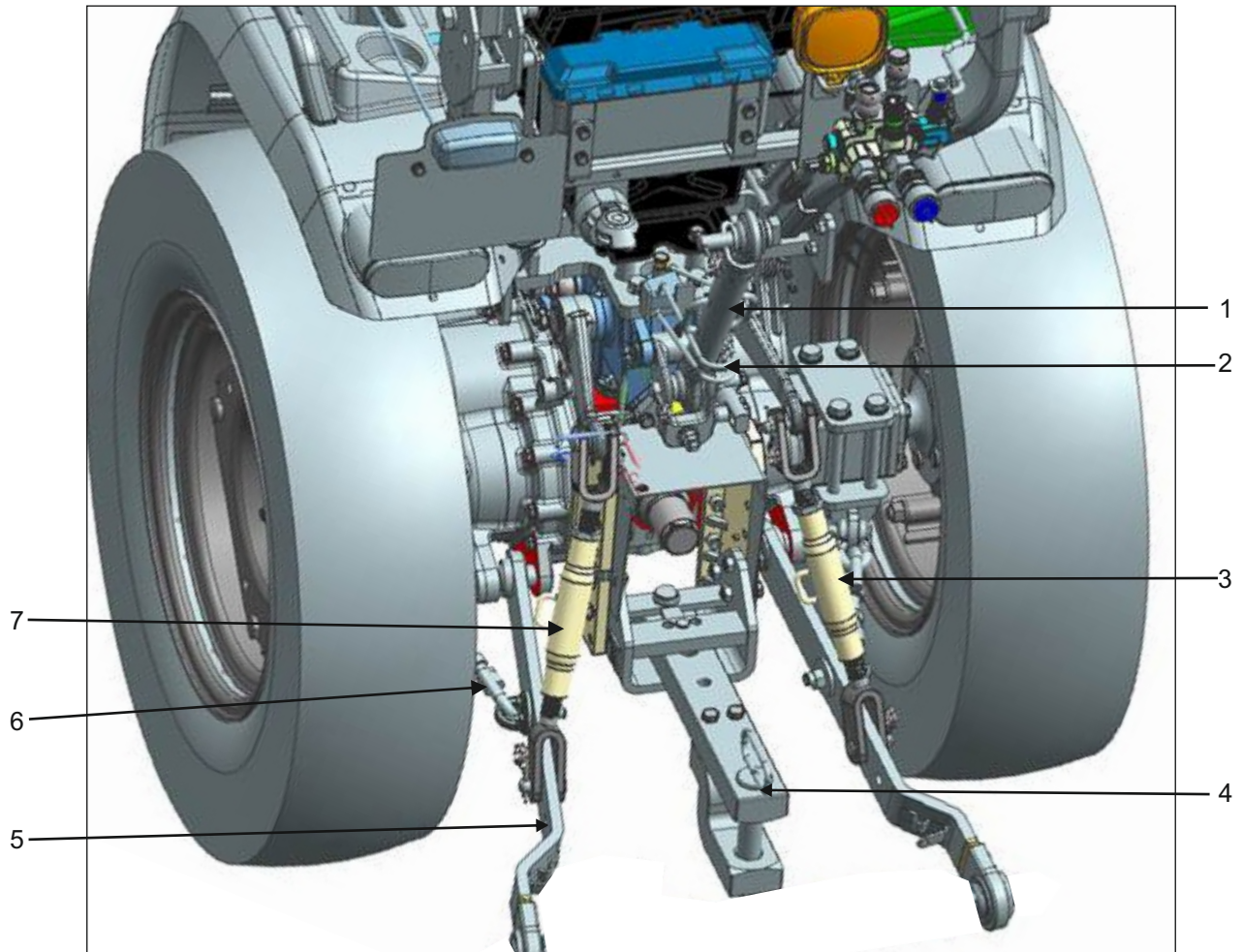

- (1) Top Link
- (2) Top Link Holder
- (3) Lift Rod (Right)
- (4) Swinging Draw-bar
- (5) Lower Link
- (6) Check Chain
- (7) Lift Rod (Left)

5.15.1 3-POINT HITCH

1. Make preparations for attaching implement.

- Selecting the holes of lifting rods and lower links

There are 3 holes in the lower links. For most operations the lifting rods should be attached to the (A) holes. Attach leveling rod to hole A for higher lifting height. Attach leveling rod to hole C for higher lifting capacity.

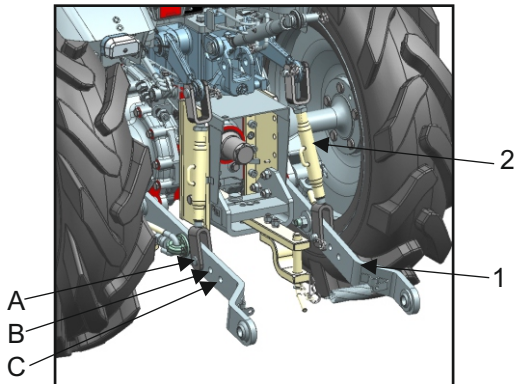

(1) Lower Link
(2) Adjustable Lift Rod

5.15.2 TOP LINK MOUNTING HOLES

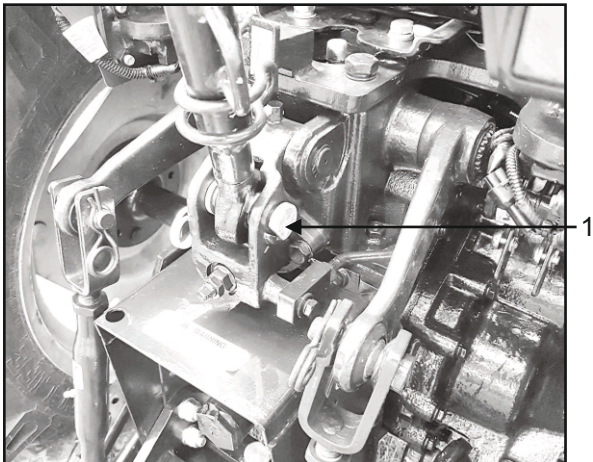

1. Top Link Mounting Hole

5.15.3 ATTACHING AND DETACHING IMPLEMENTS

⚠ WARNING

To avoid personal injury or death:

- Be sure to stop the tractor and remove the key.
- Do not stand between tractor and implement unless parking brake is applied.
- Before attaching or detaching implement, place the tractor and implement on a firm, flat and level surface.

5.15.4 LIFT ROD (LEFT & RIGHT)

Level a 3-point mounted implement from side to side by turning the adjusting handle to shorten or lengthen the adjustable lifting rod with the implement on the ground. After adjustment, tighten the lock nut securely.

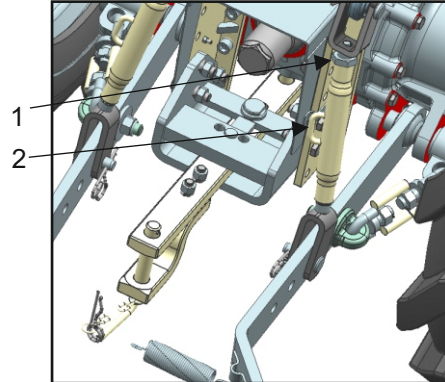

1. Lock Nut 2. Adjusting Handle

5.15.5 TOP LINK

1. Adjust the angle of the implement to the desired position by shortening or lengthening the top link.
2. The proper length of the top link varies according to the type of implement being used.

5.15.6 CHECK CHAIN

Stay bars are provided to control horizontal sway of the implement. Loose both the lynch pins to increase the sway of the implement. Now insert the lynch pins for the desired degree of sway.

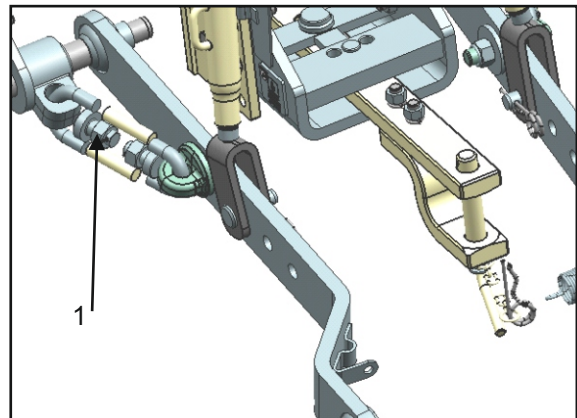

1. Check Chain

5.15.7 3-POINT HITCH CONTROL SYSTEM

⚠ **WARNING**

To avoid personal injury or death:

- Before using the 3-point hitch controls, ensure that no person or object is in the area of the implement or 3-point hitch. Do not stand on or near the implement or between the implement and tractor when operating the 3-point hitch controls.

5.16 HYDRAULIC SYSTEM

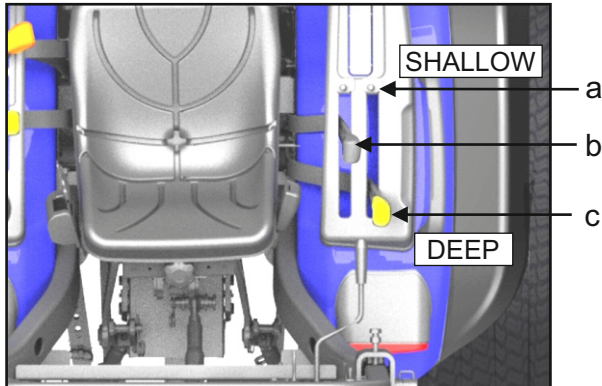

- Adjuster Stop**
- Draft Control Lever**
- Position Control Lever**

The tractor has a dual lever system, i.e., a separate lever for draft and position control functions. The draft and position control levers are used to raise or lower the three point linkage (and implement) to the required height or working depth.

⚠ WARNING : Do not transport or attach implement when the hydraulic system is in draft control. Use position control for these operations. Always lower hydraulic implement to the ground before stopping the tractor.

5.16.1 DRAFT CONTROL OPERATION

1. Move the draft control lever (b) in the quadrant to find the point near the center where the lift rods neither raise nor lower. This is the neutral position.
2. Lower the implement for engaging in the soil using the draft control lever.
3. Push the lever forward to increase the draft loading and implement depth.
4. Pull backward to reduce the draft loading and implement depth.

Once set, the tractor hydraulic system will automatically adjust the implement depth to maintain a uniform pull on the tractor and so reduce wheel slippage.

A pressure sensitive control valve installed within the hydraulic system, automatically regulates the hydraulic oil flow to give smoother response to draft signals while using soil engaging implements.

5.16.2 POSITION CONTROL OPERATION

1. Set the required implement height /depth using the position control lever.
2. Pull the position control lever © backward to raise the implement height/depth.
3. Push the position control lever forward to lower the implement height/depth.

NOTE : Implement height/depth is relative to the position of the lever in the quadrant.

4. When the required implement working height/depth has been established, set the adjustable stop to locate the position for repeated use. The adjustable stop (a) can be fixed by tightening the knob on it.
5. When transporting equipment on the three-point linkage, lock the linkages using the transport lock provided at the below of driving seat .
6. Pull the position control lever to the top of the quadrant to raise the implement quickly on turns.

IMPORTANT : Transport lock prevents accidental movement of the lever which could result in lowering of the attached implement and becoming damaged or damaging the road surface.

5.16.3 AUTOMATIC DRAFT DEPTH CONTROL (Blending Mode)

- Blending mode is a combination of draft and position control. Blending mode is used mainly for sandy or soft soil. This adjustment provides a more uniform depth while maintaining an even pull in widely varying soil conditions (the implement will not drop below the maximum set depth). Blending mode is used when final seed bed is being prepared and should not be used in 1st/2nd pass. This mode can also be used while seeding.
- Wheel slippage is controlled, high tyre life and no black smoke.
- Set the position control lever © at the maximum desired implement depth and lock the adjuster stop. The hydraulic system will not lower the implement below this depth.

NOTE : Using adjuster stop prevents "diving" which may be encountered with light implement such as a rear blade while grading or filling.

- Adjust the draft control lever (b) for the maximum desired draft load (pull). The hydraulic lift system will now provide normal draft response within the range set by the position control.

Blending Procedure :

Blending Setting operation is used only for primary type implements like MB plough, cultivator, mounted harrow, duck foot cultivator.

1. While entering into the field (tractor with implement), slowly bring the draft control downwards to achieve desired depth/draft pull.
2. Stop the tractor and run the motor at low idle rpm. Set the hydraulic stopper just below draft control lever.
3. Now engage the gear and partly release the clutch so that the implement gets loaded and all free play is eliminated.
4. Now move the position control lever upwards slowly till the point where implement gives a jerk (a point of lift). And bring back the position control lever on notch or 10 to 12 downwards.
5. Leave the lever at that position undisturbed.
6. Then use only position control lever to lift and drop the implement during turns.

5.17 TRANSPORT LOCK

⚠ **WARNING**

To avoid injury or death from crushing:

- Do not utilize the transport lock for machine maintenance or repair.
- The transport lock is to prevent accidental actuation when implement is not in use or during transport.

The control valve is equipped with a valve lock feature. The control valve is locked in the "TRANSPORT LOCK" position. The lock is not intended and will not prevent a leak down of the implement during the period of storage.

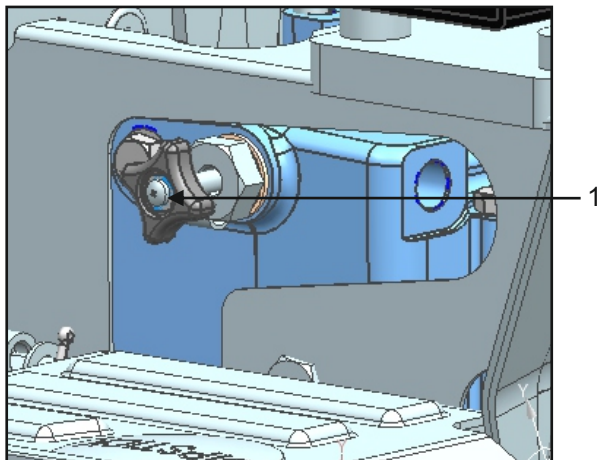

(1) Transport Lock Knob

When the knob is fully tightened by rotating it in clockwise direction to an extreme position, the lower link can be locked in the raised position and will not lower even if draft or position levers are lowered. While transporting attachments, this locking system should be used.

5.18 AUXILIARY SPOOL VALVE

To facilitate the operation of the remote cylinder, Double-Acting / Single Acting with detent Auxiliary Spool Valve is provided in tractor. It is operated by a lever located on the right-hand side of the operator's seat above the valve, which is connected by the pipe to quick-release couplers at the rear of the tractor.

NOTE : Always fix the attachment oil connections in the same ports (red or blue) so that cylinder opening and closing directions do not change with respect to the operating knob.

⚠ **CAUTION :**

Once the trailer ram is at full lift, bring back the operation lever immediately to neutral position . Keeping the lever in raised position will cause the hydraulic pump to unnecessarily run at full pressure and cause continuous blowing off system pressure and rise in temperature.

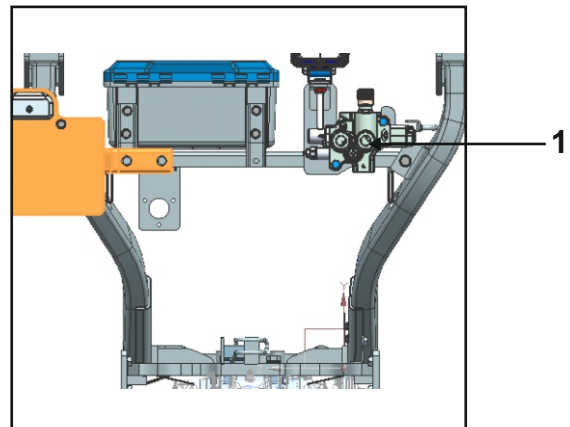

1. Double Acting / Single Acting with detent Auxiliary Spool Valve

5.19 DRAWBAR

It is used for hitching trailing implements

⚠ WARNING

To avoid personal injury or death:

- Never pull from the top link, the rear axle or any point above the draw-bar. Doing so could cause the tractor to tip over rearward causing personal injury or death.

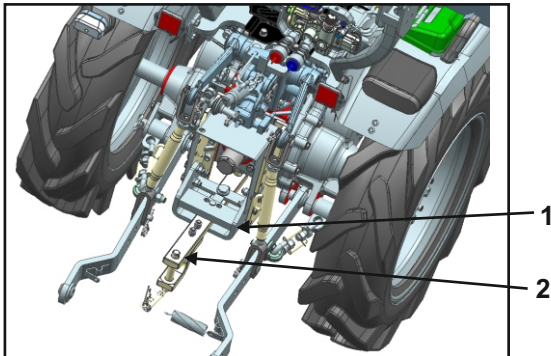

1. REAR TOW HOOK 2. SWINGING DRAWBAR

5.20 TYRES

⚠ WARNING

To avoid personal injury or death:

- Do not attempt to mount a Tyre on a rim. This should be done by a qualified person with the proper equipment.
- Always maintain correct Tyre pressure to avoid tyre wear. Do not inflate tyres above the recommended pressure shown in the operator's manual.

IMPORTANT:

- Do not use tyres other than those approved by FARMTRAC.

5.21 INFLATION PRESSURE

Though the Tyre pressure is factory-set to the prescribed level, it naturally drops slowly over the course of time. Thus, check it regularly and inflate as necessary.

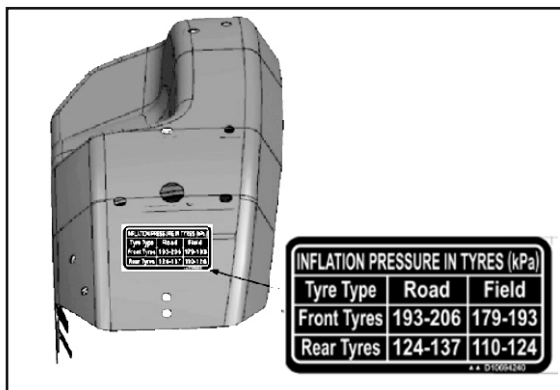

Type of Tyre	Front Tyre Pressure (kPa)	Rear Tyre Pressure (kPa)
Agri Tyre	190-200	120-140
Industrial Tyre	200-250	200-250
Turf Tyre	200-250	200-250

NOTE : Above shown pressure is for recommendation and can be adjusted further based on type of soil and surface in field or at road as per different countries' geography.

5.22 WHEELADJUSTMENT

⚠ WARNING

To avoid personal injury or death:

- When working on slopes or when working with trailer, set the wheel track width as wide as practical for maximum stability.
- Support tractor securely on stands before removing a wheel.
- Do not work under any hydraulically supported devices. They can settle, suddenly leak down, or be accidentally lowered. If necessary to work under tractor or any machine elements for servicing or adjustment, securely support them with stands or suitable blocking beforehand.
- Never operate tractor with a loose rim, wheel, or axle.

5.23 TYRES, WHEELS AND BALLAST

Front Wheels

Front track width can not be adjusted.

IMPORTANT:

- While re-fitting or adjusting a wheel, tighten the bolts to the following torques then recheck after driving the tractor 200 m (200 yards) and 10 times of shuttle movement by 5 m (5 yards).



1. Front Wheel Bolt
(Torque 110 to 130 N-m)

⚠ WARNING

To avoid personal injury or death:

- Before jacking up the tractor, park it on a firm and level ground and choke the rear wheels.
- Fix the front axle to keep it from swinging.
- Select jacks that withstand the machine weight & set them up as shown below.

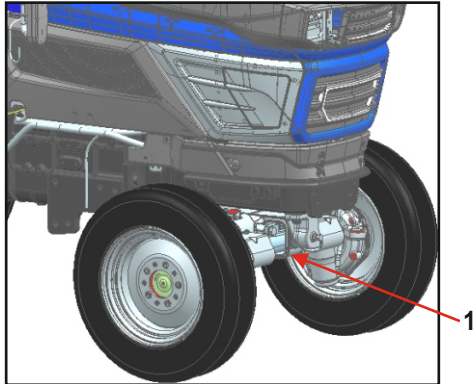

1. Jack Point



**(1) Rear Wheel Bolt
(Torque 245 To 270 N-m)**

5.24 REARWHEELS

Rear track width can be adjusted. (See " Chapter-9, Track with adjustment).

CHAPTER 6 - BATTERY & WINTER CARE

6.1. BATTERY CHARGING PROCEDURE & WARNING

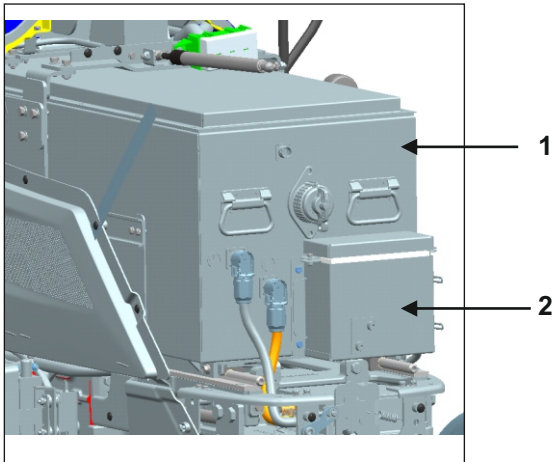

1. Main Battery (MSD)
2. Auxiliary Battery

Charge the vehicle in ventilated area, under a shade.

Step 1- Put the tractor on Parking Brake and ensure MSD is ON.



MSD "ON" POSITION

Step 2- Check voltage of auxiliary battery. Voltage should be 11 to 14V. If voltage is below 11V then charge the auxiliary battery.

Step 3- Plug the Cable into 15 Amp wall mounted socket and switch ON.



Step 4- Plug the other end on vehicle side.

Step 5- After Plug-in "Green light" will blink on RCD device, it will continue to blink if charging is happening.



RCD – Residual Charge Device

Step 6- Fan will start working on the charger side, if charging is ON.

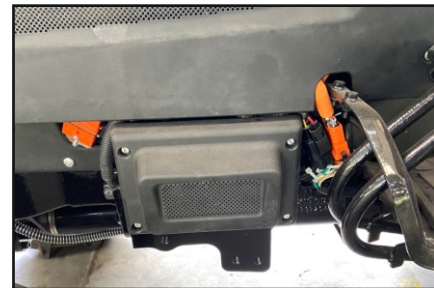

(Charger & Fan) LHS of tractor

Step 7- Switch "ON" the ignition key, battery symbol will illuminate on cluster.



RCD Charging Cable Plugged In

NOTE : Charging Source: 15 Ampere, 220V, 4 kW (Only For Tractor Charging) e. g. If charging is being conducted at home.
Total Load Required = 4kW + Other Household loads.

6.2 HOW TO INCREASE BATTERY LIFE.

- Use the battery from full charge of 100 percent to 20 percent before recharging so that no of charging cycles can be kept to minimum.
- Keep MSD "OFF" when tractor is not in use or during long storage of tractor.
- Do not operate the tractor when battery temperature goes beyond 50 degrees as shown on cluster.

6.3 HANDLING OF CHARGING CABLE

- RCD should not be in hanging position while charging . It may lead to damage of cable due to RCD unit weight.
- Store charging cable carefully. Avoid the contact of charging cable with any sharp objects. it can damage the cable.
- Check charging cable thoroughly before putting in socket.

6.4 GENERAL WARNINGS

Precautions while charging the battery -

- Do not charge the tractor in open area while it is raining or thundering.
- Do not plug in or unplug the plug with wet hands and do not stand in water, liquid or snow. This may cause an electric shock which may result in serious personal injury or death.
- Make sure the cap is closed on the charge port when charging is completed. If the charger cord is removed and the cap is open, water or foreign materials may enter the charge port.
- Make sure there is no water or foreign materials in the charge port, charge connect or electrical plug, and that they are not damaged or affected by rust or corrosion.
- Do not charge the tractor instantly after washing. Wait for 30 minutes so that tractor gets dry.

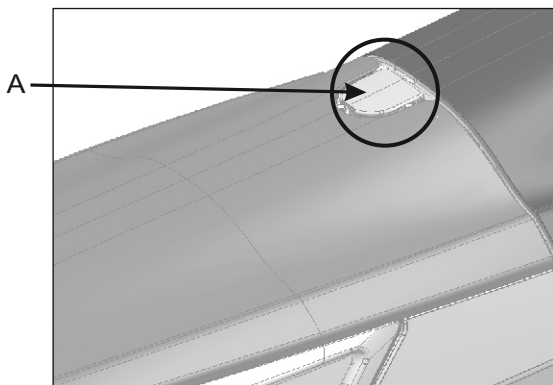

A. Charge port cap-closed condition

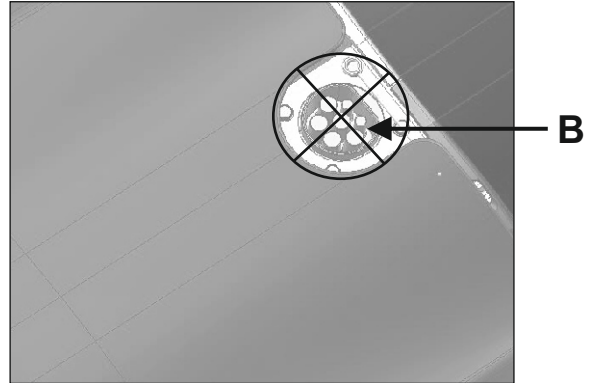

B. Charge port

6.5 WINTER CARE INSTRUCTIONS TO MAINTAIN BATTERY OPERATING TEMPERATURE IN OPERATING RANGE

- 1 After finishing the work store tractor under the roof.
- 2 In morning, check battery temperature at cluster if temperature is less than 0°C Then do not put for charge, 1st discharge the tractor till temperature raise up to 0°C then put for charge.
- 3 If you want to store tractor for long duration then please remove Auxiliary battery connection & put MSD to "OFF" & follow long storage procedure.
4. Generally put tractor for charge in night so that battery temperature maintained a limit (easy to discharge in morning).

6.6 BATTERY CHARGING PROCEDURE BEYOND 0°C

- Step1 – Park the tractor in closed shed if ambient temperature is less than zero.
- Step2 – Before charging the tractor, check the BMS (Battery Management System) temperature on cluster by making ignition key "ON".
- Step3 – If BMS temperature is below zero degree, do not charge the tractor.
- Step4 – Maintain the ambient inside shed via heater blower until BMS temperature increase to 0°C

NOTE : Tractor can work in outside condition till -10 degree ambient condition and is not advisable to work below -10°C

6.7 DO'S & DON'T

DO'S

- Keep battery away from any hazardous material such as corrosive chemicals, dangerous equipment, high-temperature environment;
- Inappropriate use of the products may result in smoke, such as external short circuit, overcharge, and high ambient temperature. If occur smoking, turn off the power supply immediately and use carbon dioxide or dry powder fire extinguishers. Suggest to bury the battery with sand or soil if necessary. The whole process need to accompany timely evacuation alarm (if necessary);
- Inappropriate use of the products may lead to single cells bumping, severe cases may cause the Aluminum-plastic pouch breaks or cracks, immediately stop using the battery
- Do not allowed to disassemble, crush, puncture, or high-temperature baking battery. Please avoid excessive amplitude vibration, external shocks, such as high drop, this could result in bodily injury or property damage.
- Keep away the battery from children and people who don't have knowledge of Lithium ion battery safety use.

DON'T

- Prohibit directly positive and negative short circuit, avoid contacting battery terminal by any metal or other conductive object other than a bolt and a conductive strip to contact the battery terminal. This may lead to personal injury or property damage
- Prohibit exposing the battery in high temperature (≥ 55 °C) environment for long time, prohibit to heat the battery in a fire which could result in bodily injury or property damage
- Prohibit to charge battery without BMS (Battery Management System) or use non-approved Charger to charge the battery pack, this may cause personal injury or property damage
- Prohibit to Immerse the battery into water or other conductive liquid, this may lead to personal injury or property damage
- Do not try to connect the battery pack in series or in parallel with other models or types of batteries, this may lead to personal injury or property damage; Prohibition to connect different battery pack in series or in Parallel.

USER INSTRUCTIONS

- Recommended operating temperature(Discharging) : -10 °C ~55 °C
- Recommended operating temperature (Charging) : 0 °C ~ 55 °C
- Cell voltage Range : NMC: 3.0V ~ 4.2V
- Battery fault alarm signal transmitted by the battery BMS to the Vehicle control unit.
- Every time before driving, Check the SOC, It is recommended to use SOC value 50% to 100%; When the SOC value is less than 30%, Recommend to charge the battery SOC till 50% to 100%
- The battery factory departure status is normally 40%-60%, it recommend to charge to be SOC 50%-80% for storage.
- Recommend to fully charge the battery after battery pack mounting on the vehicle.

6.8 WORKING OF CHARGING CIRCUIT

For successful working of charging system ensure below conditions:

- MSD should be in ON position.
- 12V battery voltage should be above 11V.
- Foot and hand throttle and brake should not be pressed.
- Charging socket should be inserted after 7seconds of turning power supply ON

Following all the conditions given above, once the charging is plugged in 12V signal goes to charge drive interlock relay which commands KSI relay to stop giving output to controller for waking up. Hence the controller will not wake up when charging is plugged in. Also, a 12V signal goes to BMS to wake it up for charging and then charging starts.

6.9 MAINTENANCE

The first month will be the run-in period, after the run-in period, Do a thoroughly inspection. Then do yearly inspection regularly.

Inspection content:

Item	Detection method	Criteria
Clean the battery box	Compressed air law	The box should have no clogging of dust
Cable between the housing / connector	Visual	Cables and Connectors tightly connected to the insulating layer and the cable cover is not damaged
The housing and the frame mounting bolts	Visual	Fixing bolt tightening fixed without ANY loss
Battery Box reliability	Visual	Battery Box without any cracks, deformation, pole loosen or other abnormal. All external fixing bolts and nuts are not loose, missing, deformation.
Cell temperature detection	BMS data read	Cell surface temperature should be consistent with the current ambient temperature when battery is static
System temperature difference	BMS data read	Static temperature difference is less than 8
Battery consistency	BMS data read	Static voltage difference within the allowable tolerance (SOC less than 10% monomer)
SOC (State of Charge) deviation	BMS data read	SOC deviation should be within the allowable range (SOC display and The actual voltage difference less than 10% SOC).
System Insulation Resistance	BMS data read	Insulation value $\geq 500\Omega / V$

6.10 TROUBLESHOOTING

Preconditions:

- 1 Source should be single phase AC with proper earthing.
- 2 MSD should be in ON condition.
- 3 Insert the socket at tractor side only after 7seconds of switching On the supply.

If there is an issue in charging check following things:

- 1 Check the 230V source, check if 230V is coming on the socket side or not. If 230V is not coming between phase and neutral or phase and earthing then change the voltage source.
- 2 Check if MSD is in ON position or not.
- 3 Check if BMS 12pole connector is properly connected or not.
- 4 Check voltage between C and D pin of BMS 12 pole connector. If the voltage is not 12V then check all the charging harness connectors specially the 2pole DIS connector as shown.

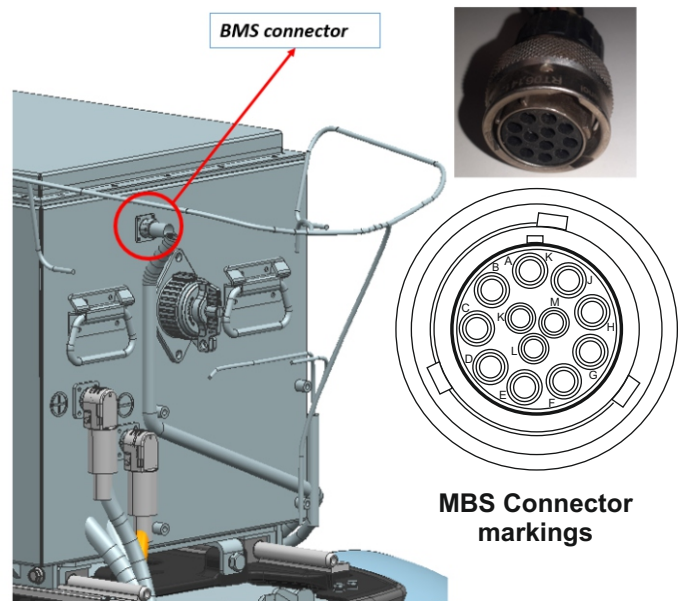

6.11 BATTERY STORAGE PROCEDURE FOR LONG TIME

This procedure will help you to keep main battery (73VDC, 350AH) for longer time.

Important Safety Instructions

1. Keep battery away from any hazardous material such as corrosive chemicals, dangerous equipment, high-temperature environment.
2. Inappropriate use of the products may result in smoke, such as external short circuit, overcharge, high ambient temperature. If smoking occurs, turn off the power supply immediately and use carbon dioxide or dry powder fire extinguishers. Suggest to bury the battery with sand or soil if necessary. The whole process need to accompany timely evacuation alarm (if necessary).
3. In appropriate use of the products may lead to single cells bumping, severe cases may cause the Aluminum-plastic pouch breaks or cracks, immediately stop using the battery .please contact Sound on to Analysis the root cause and wait M/s Soundon detail.
4. Prohibit directly positive and negative short circuit, avoid contacting battery terminal by any metal or other conductive object other than a bolt and a conductive strip to contact the battery terminal. This may lead to personal injury or property damage.
5. Prohibit to charge battery without BMS or use non-approved Charger to charge the battery pack, this may cause personal injury or property damage.
6. Prohibit to Immerse the battery into water or other conductive liquid, this may lead to personal injury or property damage.
7. Keep away the battery from children and people who don't have knowledge of Lithium ion battery safety use.

6.12 STORAGE RECOMMENDATIONS

If SOC <= 10%,	Charged immediately
If 10% < SOC <= 40%	Each 1 month periodic charging
If 40% < SOC <= 80%	Each 3 months, periodically charging
If 80% < SOC <= 100%	Each 6 months, periodically charging time

CHAPTER 7 - WARRANTY & SERVICING OF TRACTOR

7.1 WARRANTY & SERVICING OF TRACTOR

Your FARMTRAC Dealer / Distributor is interested to support your new tractor and has the desire to help you get the most value from it. After reading this manual thoroughly, you will find that you can do some of the regular maintenance yourself. However, when you are in need of parts or major service, be sure to contact your FARMTRAC Dealer / Distributor.

For service, contact the FARMTRAC Dealership from which you purchased your tractor or your local FARMTRAC Dealer / Distributor.

When in need of parts, be prepared to give your Dealer / Distributor the tractor, ROPS and battery serial numbers.

	Type	Serial No.
Tractor		
ROPS		
Battery		
Date of Purchase		
Name of Dealer		
(To be filled in by purchaser)		

◆ Warranty

- This tractor is warranted under the FARMTRAC Limited Express Warranty, a copy of which may be obtained from your selling Dealer / Distributor. No warranty shall, however, apply if the tractor has not been handled according to the instruction given in the Operator's Manual even it is within the warranty period.
- Scrapping the tractor and its procedure To put the tractor out of service, correctly follow the local rules and regulations of the country or territory where you scrap it. If you have questions, consult your local FARMTRAC Dealer / Distributor.

◆ Servicing The Tractor

- Before servicing the tractor, park it on a firm, flat and level surface, set the parking brake, lower all implements to the ground, place the gear shift lever in neutral, stop the tractor and remove the key.
- Always maintain the correct tyre pressure. Do not inflate tyres above the recommended pressure shown in the operator's manual
- If any high heat condition or burning smell is noticed immediately park the tractor in a safe location, place the ignition in the OFF position, move your self a way quickly to a safe distance from the tractor and contact your dealer for assistance and repair

- Do not store your tractor in side if any of the above noted conditions exist.
 - Do not attempt to alter the tractor in any manner which would affect stability, control, or top speed. Such alterations may lead to serious injury or death, violate state and local laws, and will void the manufacturer's warranty
1. Switch off MSD (Manual Service disconnect) Switch.

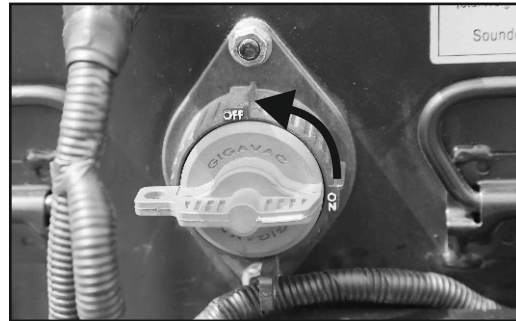

2. Disconnect the 12 volt battery supply.



3. Put the FNR (forward, neutral & Reverse) switch at neutral position.
4. Switch off all the dash board switches shown below.

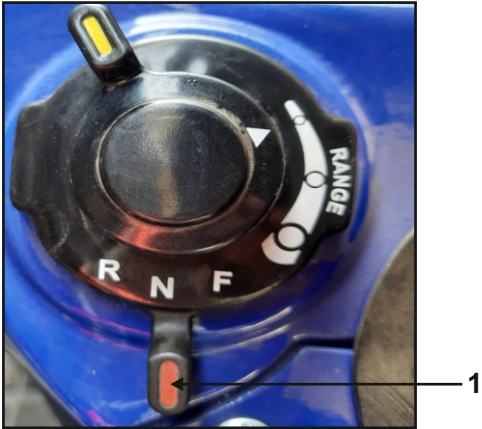

1. FNR in Combination with SNF Switch

Use the handle to remove the battery.

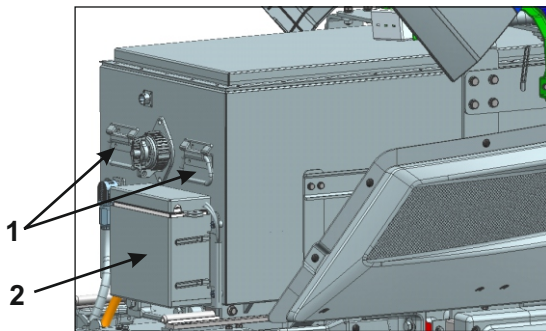

- 1. Handle
- 2. 12 V Auxiliary Battery

1. Make sure that wheel bolts have been tightened to the specified torque.
2. Do not work under any hydraulically supported devices. They can settle, suddenly leak down, or be accidentally lowered. If it is necessary to work under tractor or any machine elements for servicing or adjustment, securely support them with stands or suitable blocking beforehand.
3. Escaping hydraulic fluid under pressure has sufficient force to penetrate skin, causing serious personal injury. Before disconnecting hydraulic lines, be sure to release all residual pressure. Before applying pressure to the hydraulic system, make sure that all connections are tight and that all lines, pipes, and hoses are free of damage.



CHAPTER 8 - IMPLEMENT RECOMMENDATIONS

8.1 IMPLEMENT RECOMMENDATIONS

The FARMTRAC Tractor has been thoroughly tested for proper performance with implements sold or approved by FARMTRAC. Use with implements which are not sold or approved by FARMTRAC and which exceed the maximum specifications listed below, or which are otherwise unfit for use with the FARMTRAC Tractor may result in malfunctions or failures of the tractor, damage to other property and injury to the operator or others. [Any malfunctions or failures of the tractor resulting from use with improper implements are not covered by the warranty.]

Lower link end max. loading weight is 450kg. The max. allowable load which can be put on the lower link end : W0
 The implement's weight which can be put on the lower link : W1 (As in the following list shown on the next page.

Max. drawbar load 253kg (W2).



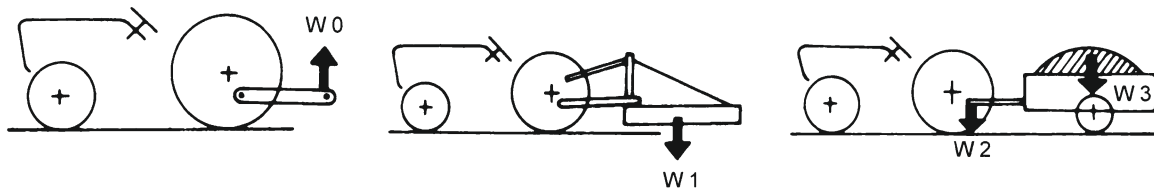





Trailer loading weight is 1500kg The max. loading weight for trailer (without trailer's weight): W3



NOTE:

- Implement size may vary depending on soil and operating conditions.
- Strictly follow the instructions outlined in the operator's manual of the mounted or trailed machinery or trailer, and do not operate the combination tractor - machine or tractor - trailer unless all instructions have been followed.
- For drawbar applications (plough, harrow, cultivator etc.), use of 4 wheel drive mode is mandatory for better traction & durability.

IMPLEMENT RECOMMENDATIONS

Implement Name	Description	Range	SNF	Motor RPM
Cultivator	 5 Tyne	Medium	S	1700-2000
Rotavator	 0.8 m, 16 Blades L type	Low 540E PTO	F	2200-2500
Rear Mower	 Max cutting width-60"	Low Rear PTO	S	1200-1500
Trailed Sprayer	 400 LITRE	Low 540 PTO	F	2400-2500
Mounted Sprayer	 MIST BLOWER, 200 Liter	Low 540 PTO	F	2400-2500
MB Plough	 2 Bottom , Non Reversible 8-10" board	Low	N	1500-2000
Disc Harrow	 5x5 DISCS 20"	Medium	N	2000
Trailer	 1.5 Ton Capacity including trailer weight	High	F	-
Front Loader	 180 KG Bucket Capacity 1.2 m Bucket, Light Duty	-	-	-

CHAPTER 9 - SPECIFICATION

9.1 SPECIFICATION

PARAMETERS	FARMTRAC 25 G
Motor & Controller	
Motor Type	Three Phase AC induction Motor
Motor Power Rating	25HP Category
Motor Rated Torque	84 Nm @1700 RPM
Max. Torque	90 Nm
Controller Type	Speed Or Torque Mode (200A)
Battery Pack	
Cell Model	Lithium Nickel Manganese Cobalt (NMC)
Technology	Li-ion
Pack capacity	350 AH
Charging Voltage	82 VDC
Battery Life	2500 Cycles @25°C
Battery Charging Time	8 Hours from 0 to 100% @ (On for charger)
Battery Charger	
Input Voltage	AC85-265V
Frequency	45-65 Hz
Max. DC output Power	3.3KW@220VAC
IP rating	IP 67
PTO	
Engagement Type	PTO ON-OFF - Wet Clutch Switch
PTO Speed @ ERPM	540@ 2504 PTO : ~ 12-13 HP 540E@2035 PTO : ~ 12-13 HP
PTO Power	15-16 HP@1800 RPM
Transmission	
No. Of Gears	3 Range Transmission
Rear Axle Reduction Type	Bull Gear
Differential Lock	Yes
Brakes	
Type	Oil Immersed
Parking Brake	With Independent lever
Plate Size & No.'s	4.5" & 3
3 Point Linkage	
TPL category	Cat 1N
Hydraulics	
Function	Position Control & Draft Control
Lift Capacity	450 Kg
Hydraulic Pump CC (lift/ Steering)	5.5 CC (with flow divider For steering)
Hydraulic Pump Capacity (Lift/Steering)	14.4 lpm (Lift& Steering Common)
Auxiliary Valves	1DA/SA Convertible with Detent
Front Axle	
Type	4WD
Tyres	
Front tyre	23*8.50-12 Turf
Rear tyre	33*15.5-16.5 Turf
Optional tyres	Agri, Industrial, Radial

SPECIFICATION

Dimensions(mm)	Agri	Turf	Industrial	Radial
Length (ROPS Folded Conditions)	3125 mm	3125 mm	3125 mm	3125 mm
Length (ROPS Unfolded Conditions)	2650 mm	2650 mm	2650 mm	2650 mm
Height (ROPS Folded Conditions)	1438 mm	1395 mm	1401 mm	1402 mm
Height (ROPS Unfolded Conditions)	2008mm	1966 mm	1970 mm	-
Width	1080 mm	1470 mm	1470 mm	1171 mm
Wheelbase	1550 mm	1550 mm	1550 mm	1550 mm
Track Width Front	841 mm	933mm	933 mm	841 mm
Track Width Rear	841 mm	1172 mm	1176 mm	841 mm
Other Features				
Wet Clutch On/off Switch , Lift mode selection Switch, Pump on/Off Switch, Operator Presence Switch, Safety Neutral Switches At Forward/Reverse Mode And at PTO .				

TRAVELLING SPEEDS

TRACTOR SPEED	RANGE	Km/Hr @ MOTOR RPM		
		AGRI 8.3x20	TURF 33x15.5-16.5	INDUSTRIAL 33x15.5-16.5
Forward Speed Range (Km/Hr)	Low	0-2.9 @ 2800 rpm	0-2.7 @ 2800 rpm	0-2.7 @ 2800 rpm
		0-2.6 @ 2500 rpm	0-2.4 @ 2500 rpm	0-2.4 @ 2500 rpm
		0-2.1 @ 2000 rpm	0-1.9 @ 2000 rpm	0-1.9 @ 2000 rpm
	Medium	0-9.3 @ 2800 rpm	0-8.6 @ 2800 rpm	0-8.6 @ 2800 rpm
		0-8.3 @ 2500 rpm	0-7.7 @ 2500 rpm	0-7.7 @ 2500 rpm
		0-6.7 @ 2000 rpm	0-6.1 @ 2000 rpm	0-6.1 @ 2000 rpm
	High	0-18.5 @ 2800 rpm	0-17.0 @ 2800 rpm	0-17.0 @ 2800 rpm
		0-16.5 @ 2500 rpm	0-15.2 @ 2500 rpm	0-15.2 @ 2500 rpm
		0-13.2 @ 2000 rpm	0-12.1 @ 2000 rpm	0-12.1 @ 2000 rpm
Reverse Speed Range	Low	0-2.3 @ 2200 rpm	0-2.1 @ 2200 rpm	0-2.1 @ 2200 rpm
		0-2.1 @ 2000 rpm	0-1.9 @ 2000 rpm	0-1.9 @ 2000 rpm
	Medium	0-7.3 @ 2200 rpm	0-6.7 @ 2200 rpm	0-6.7 @ 2200 rpm
		0-6.7 @ 2000 rpm	0-6.1 @ 2000 rpm	0-6.1 @ 2000 rpm
	High	0-14.5 @ 2200 rpm	0-13.3 @ 2200 rpm	0-13.3 @ 2200 rpm
		0-13.2 @ 2200 rpm	0-12.1 @ 2200 rpm	0-12.1 @ 2200 rpm

NOTE : Tyre of similar make and size to be used and non compliance may result in incorrect slip of front and rear tyre and hence excessive tyre wear, drive line failure may happen.

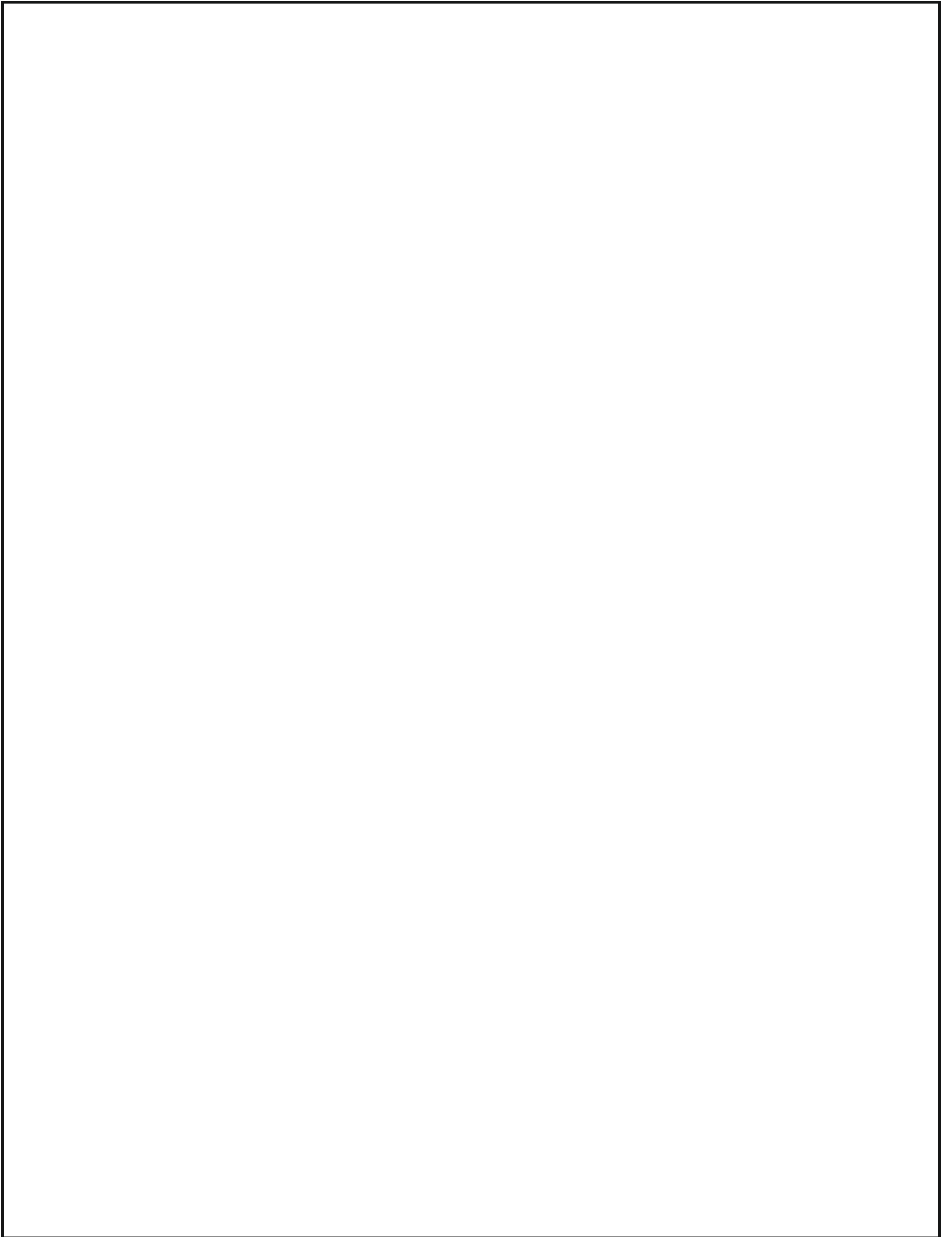

9.2 TRACK WIDTH OPTIONS FOR AGRICULTURAL REAR TYRES

Rear Tyre Size 8.00- 18

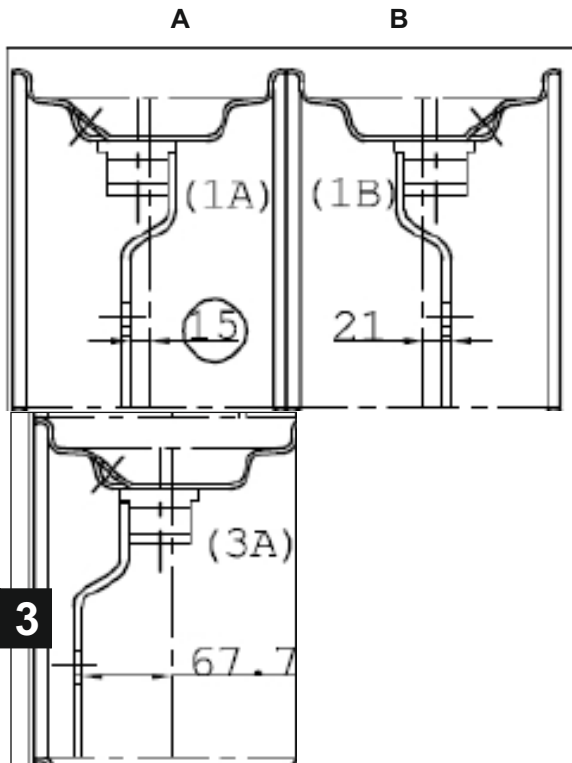

Tyre Size	8x18	
	TRACK WIDTH	
CONDITION	MM	IN
1A	825.0	32.4
1B	897.0	35.3
3A	719.6	28.3

Front Track Width (Turf & Ind.)

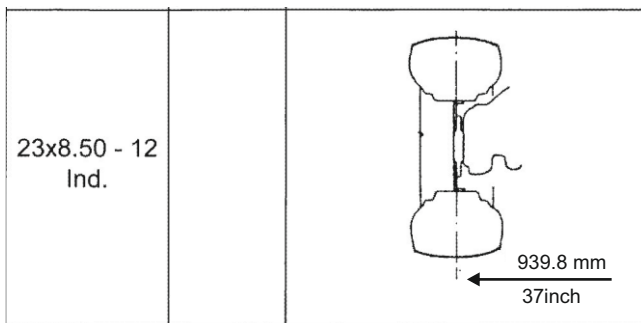
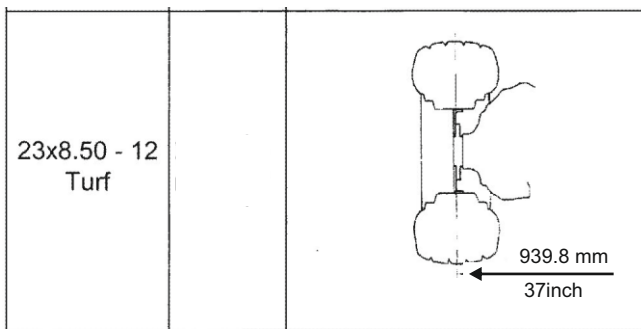

Rear Track Width (Turf & Ind.)

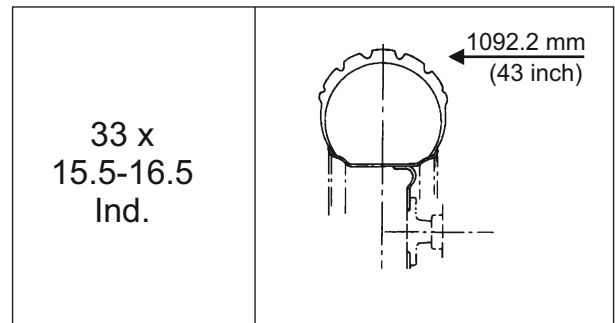
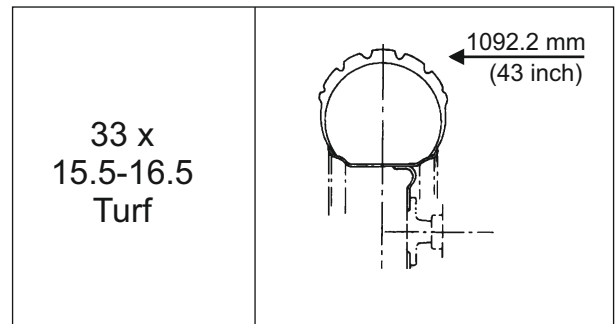

NOTE : With turf and industrial tyre, track width adjustment is not recommended.

BALLAST

◆ Front Ballast (Optional)

Four numbers of front end weights can be attached with hanger for stability and improving traction. Heavy pulling and heavy rear mounted implements tend to lift front wheels.

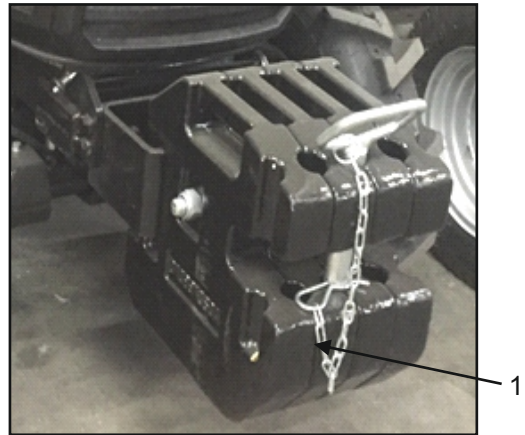
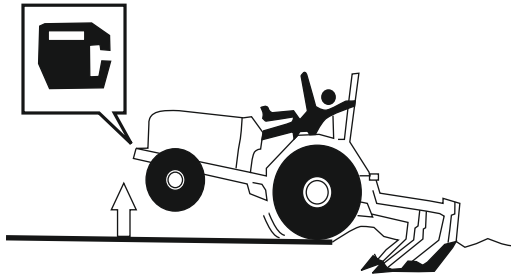

1. Front End Weight

NOTE:

[For installation of up to 4 weights]

- Besides the weight, mounting bolt kits are required for mounting the weight.

IMPORTANT:

- Do not overload tyres.
- Add no more weight than indicated in below chart. Maximum

Maximum weight	30 kg x 4 pieces (120 kg)
----------------	---------------------------

CHAPTER - 10 LUBRICATION AND MAINTENANCE

10.1 SERVICE INTERVALS

Sr. No.	Items	Activity	Indication on Hour Meter					Service Interval
			50	300	550	800	1050	
1	Transmission Oil	Replace				✓		First at 800 hrs. than at every 1000 hours.
2	Front Axle Case Oil	Replace		✓		✓		First at 300 hrs. than at every 500 hours.
3	Front axle Pivot	Adjust	✓	✓	✓	✓	✓	At Each Service
4	Greasing		✓	✓	✓	✓	✓	1. In normal Condition every 50 hrs 2. In muddy or Puddling Conditions Daily
5	Wheel Bolt Torque	Check	✓	✓	✓	✓	✓	On Every Service
6	Battery Condition	Check	✓	✓	✓	✓	✓	On Every Service
7	Brake	Adjust	✓	✓	✓	✓	✓	On Every Service
8	Toe-in	Adjust	✓	✓	✓	✓	✓	On Every Service
9	Fuse	Replace						Check on every service, replace as & when required
10	Light Bulb	Replace						
11	Hydraulic Strainer	Clean	✓	✓	✓	✓	✓	At every service interval
12	Hydraulic Strainer	Replace				✓		First at 800 hrs and than at every 750 hours.
13	Water in Front Housing	Check	✓	✓	✓	✓	✓	On Every Service

LUBRICATION AND MAINTENANCE OIL CHART

S.No.	Description	Type/Grade	Quantity (litre)
1	Gear Box oil	UTTO	17
2	Rear Axle Oil and Power Steering		
3	Front Axle Oil Differential Housing	SAE 80 W / SAE 80W90	3.2

NOTE : Top up in oil is permissible for limited oil quantity i.e. rear axle- 2-3 liter & front axle - 0.5 liter. For large quantity oil change (more than the above specified limit), change completely with same grade of oil mentioned above.

10.2 HOW TO OPEN THE HOOD

⚠ **WARNING**

To avoid personal injury or death from contact with moving parts;

- Never open the hood or side cover while the tractor is running.
- Do not open the hood while charging the tractor.

◆ **Hood**

◆ **Open the hood**

1. Insert the key to open the hood.
2. Rotate the key in clockwise direction.

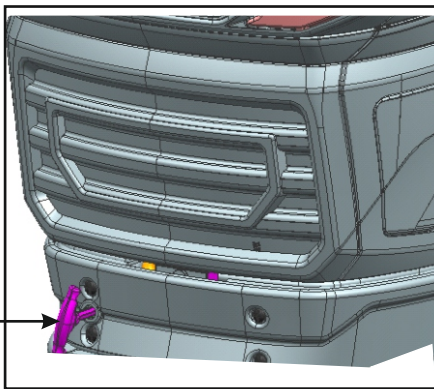

1. Key

2. Open the hood by holding its bottom with both hands.

◆ **Close the hood**

1. Hold the hood with both hands and push it down.



2. In closing the hood, use both hands again.

10.3 DAILY CHECK

⚠ **WARNING**

To avoid personal injury or death:

Take the following precautions when checking the tractor.

- Park the machine on firm and level ground.
- Set the parking brake.
- Lower the implement to the ground.
- All residual pressure of the hydraulic system released.
- Stop the tractor and remove the key.

◆ **Walk Around Inspection**

Look around and under the tractor for such items as loose bolts, trash build-up, oil or coolant leaks, broken or worn parts.

◆ **Checking Transmission Fluid Level**

1. Park the machine on a flat surface, lower the implement and shut off tractor.
2. To check the oil level, remove the dipstick cover, draw out the dipstick, wipe it clean, replace it, and draw it out again. Check to see that the oil level lies within the cross hatched area. If the level is too low, add new oil to the prescribed level at the oil inlet. (See "LUBRICANTS" in "MAINTENANCE" section.)

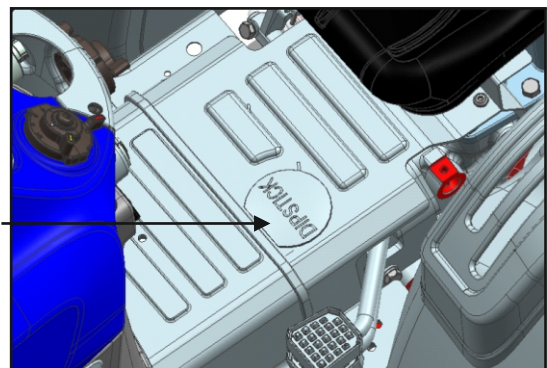

1. Dipstick Cover

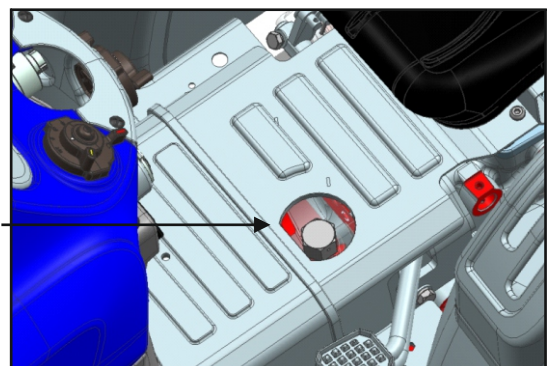

1. Dipstick

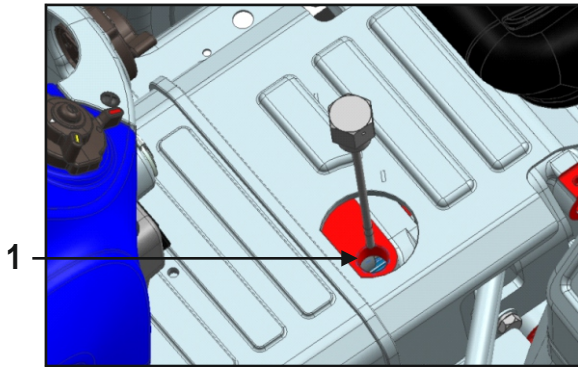

1. Transmission Oil Dipstick Cum Oil Filling Port

◆ **Checking Brake Pedal**

1. inspect the brake pedals for free travel, and smooth operation.
2. Adjust if incorrect measurement is found:
(See "Adjusting Brake Pedal" in "on EVERY SERVICE" in "PERIODIC SERVICE" section.)

◆ **Checking Gauges, Meter and Instrument Cluster**

1. Inspect the instrument panel for broken gauges, meters and Easy Checker (TM).
2. Replace if broken.

◆ **Checking Head Light, Hazard Light etc.**

1. Inspect the lights for broken bulbs and lenses.
2. Replace if broken.

◆ **Checking Seat Belt and ROPS**

1. Always check condition of seat belt and ROPS attaching hardware before operating tractor.
2. Replace if damaged.

◆ **Checking and Cleaning of Electrical**

Wiring and Battery Cables

⚠ WARNING

To avoid personal injury or death:

- A loosened terminal or connector, or damaged wire may affect the performance of electrical components or cause short circuits. Leakage in electrical system could result in a fire hazard, a dead battery or damage to electrical components.
- Replace damaged wires or connections promptly.
- If a fuse blows soon after replacement, **DO NOT USE A LARGER THAN RECOMMENDED FUSE OR BYPASS THE FUSE SYSTEM.**
- Many wiring connections are protected by waterproof plugs, plug and unplug these connections carefully and make sure they are sealed correctly after assembly.
- Accumulation of dust, chaff or spilled fuel deposits around the battery, electrical wiring. **CLEAN THESE AREAS BEFORE STARTING WORK.**

To avoid premature electrical malfunctions **DO NOT APPLY** high pressure water directly to battery, wiring, connectors, electrical components or instrument panel.

◆ **Checking Movable Parts**

If any of the movable parts, such as levers and pedals, is not smoothly moved because of rust or sticky material, do not attempt to force it into motion.

In the above case, remove the rust or the sticky material, and apply oil or grease on the relevant spot, other wise the machine may get damaged.,

10.4 EVERY 50 HOURS

• **Lubricating Grease Fittings**

Apply a small amount of multipurpose grease to the following points every 50 hours:

If you operated the machine in extremely wet and muddy conditions, lubricate grease fittings more often.

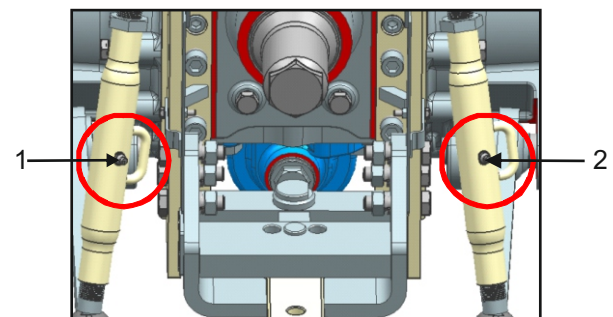

1,2 Grease Point (Lifting Rod)

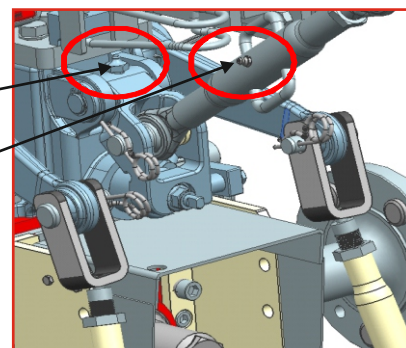

3. Grease Point (Top Link Mounting Bracket)
4. TOP Link

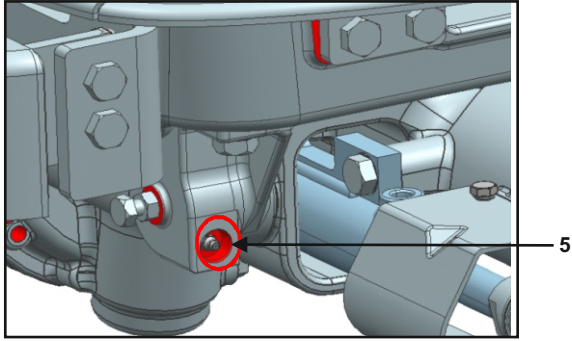

5. Grease Point (4WD Front Axle)

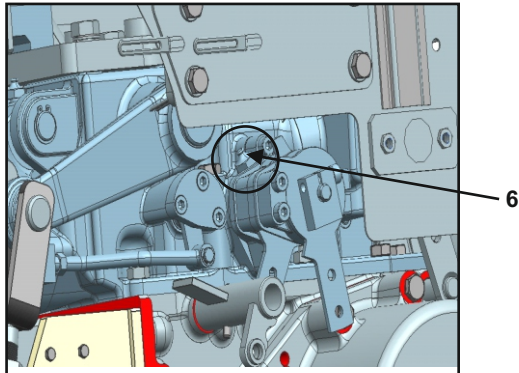

6. PC Sector on Hydraulic Housing

10.5 ON EVERY SERVICE

Checking Wheel Bolt Torque



1. 110 to 130 N-m. 2. 245 to 270 N-m.

10.6 AUXILIARY BATTERY

- Checking Battery Condition
- Never check battery charge by placing a metal object across the posts. Use a voltmeter or hydrometer.

⚠ WARNING

To avoid personal injury or death:

- Keep open sparks and flames away from the battery at all times. Hydrogen gas mixed with oxygen becomes very explosive.
- Wear eye protection and rubber gloves when working around battery. Mishandling the battery shortens the service life and adds to maintenance costs.
- The original battery is maintenance free.
- It is important to check the battery periodically.

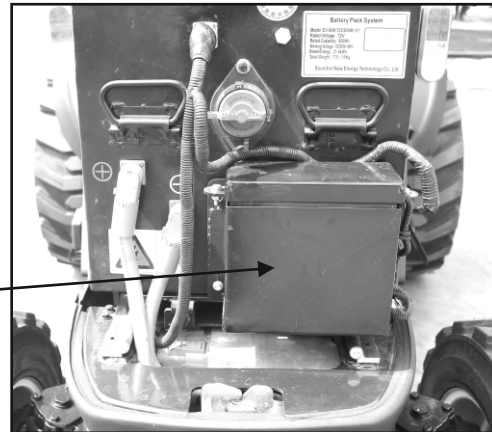

1. Auxiliary Battery

10.7 AUXILIARY BATTERY CHARGING

For charging use power supply with following characteristics:

- 1KW
- 220 V input
- 13.5 V Output
- 5 Ampere

⚠ WARNING

To avoid personal injury or death:

- When the battery is being activated, hydrogen and oxygen gases in the battery are extremely explosive. Keep open sparks and flames away from the battery at all times, especially when charging the battery.
1. When exchanging an old battery for a new one, use battery of equal specification shown in table 1.

10.8 AUXILIARY BATTERY CUT-OFF SWITCH

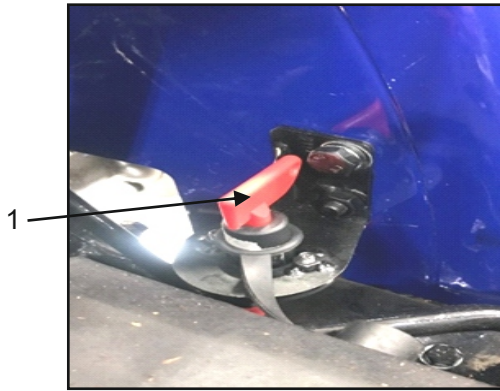

1. Auxiliary Battery Cut-off Switch

◆ Use of Battery Cut-off switch

- To avoid early discharge of 12 V Auxiliary battery, use the Cut-off Switch.
- Cut-off the switch while tractor is not use.
- Battery Cut-off switch has 3 position given in below image.
- Battery Cut-off switch is located on LHS fender.
- Operation of switch is expressed in given images.

1. Switch-Concealed with cap.
2. Knob in Un-Lock-Position.

- Disconnect the 12V battery supply while storage to increase the life of auxiliary battery by rotating

◆ Operation of battery Cut-off switch

- Battery Cut-off switch is located on LHS Fender-Quick reach to operator
- Operation of switch is expressed in following images.



Switch-Concealed with cap

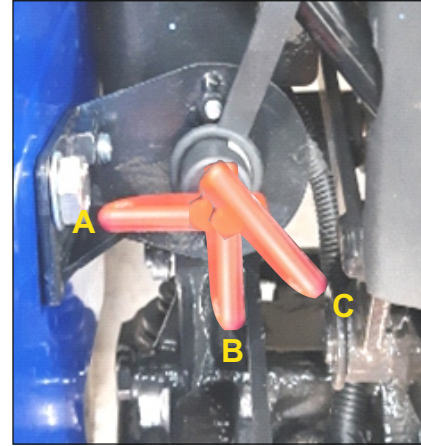

- A. ON-Position**
- B. OFF-Position**
- C. Knob UN-Lock Position**

10.9 ADJUSTING BRAKE PEDAL

⚠ WARNING

To avoid personal injury or death:

- Stop the tractor and choke the wheels before checking brake pedal.

1. Release the parking brake.
2. Slightly depress the brake pedals and measure free travel at the top of pedal stroke.
3. If adjustment is needed, loosen the lock nut and turn the turnbuckle to adjust the rod length within acceptable limits.
4. Re-tighten the lock nut.

Proper brake pedal free travel	25 mm on the pedal
	Keep the free travel in the right and left brake pedals equal.

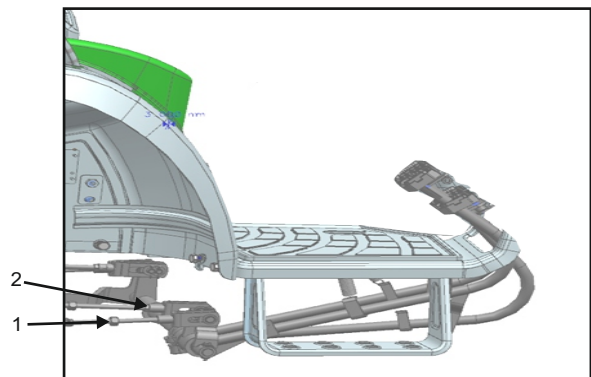

1. Lock Nut 2. Turn Buckle

10.10 ADJUSTING TOE-IN

1. Park tractor on a flat place.
2. Turn steering wheel so front wheels are in the straight ahead position.
3. Lower the implement, lock the park brake and stop the tractor.
4. Measure distance between tyre beads at front of tyre, hub height.
5. Measure distance between tyre beads at rear of tyre, hub height.
6. Front distance should be 4 to 12 mm (0.15 to 0.47 in.) less than rear distance. If not, adjust tie rod length.

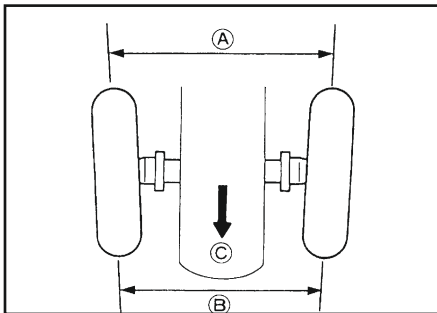

A. Wheel to Wheel at Rear B. Wheel to Wheel at Front
C. FRONT

10.11 ADJUSTING PROCEDURES

1. Loosen the tie-rod nut.
2. Turn the tie-rod joint to adjust the rod length until the proper toe-in measurement is obtained.
3. Retighten the tie-rod nut.

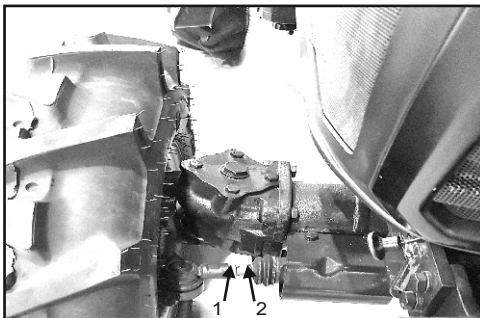

1. Tie-rod Nut 2. Tie-rod Joint

10.12 ADJUSTING FRONT AXLE PIVOT (4WD)

⚠ WARNING

To avoid personal injury or death:

- Park the tractor on a flat place.
- Lower the implement, lock the parking brake and stop the tractor.

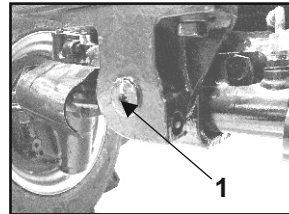

1. Front Axle Pivot

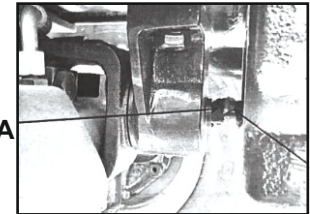

Adjusting the Front Axle Pivot

PROCEDURE :

1. Loosen the lock nut (A). Tighten adjusting screw (B) So that the oscillating load is 100-150N (10-15 kgf).
2. Tighten lock nut (A) to 40-50 Nm.
3. Check & adjust at every service.

10.13 CHECKING HYDRAULIC STAINER

1. Check to see that all lines and hose clamps are tight and not damaged.
2. If hoses and clamps are found worn or damaged, replace or repair them at once.

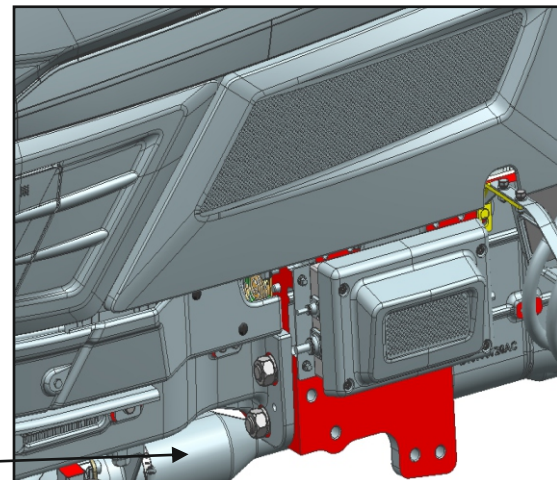

1. Hydraulic Stainer

AT FIRST 800 HOURS (SUBSEQUENT EVERY 1000 HRS.)

10.14 CHANGING TRANSMISSION FLUID

⚠ WARNING

To avoid personal injury or death;

Park the tractor at plain and clean surface.

1. To drain the used oil, remove the drain plug at the bottom of the transmission case and drain the oil completely into the oil pan.
2. After draining reinstall the drain plug.
3. Fill with new FARMTRAC UTTO fluid up to the upper limit on the dipstick.

(See "LUBRICANTS" in "MAINTENANCE" section and "DAILY CHECK" in "PERIODIC SERVICE" section)

4. Properly dispose of used oil.

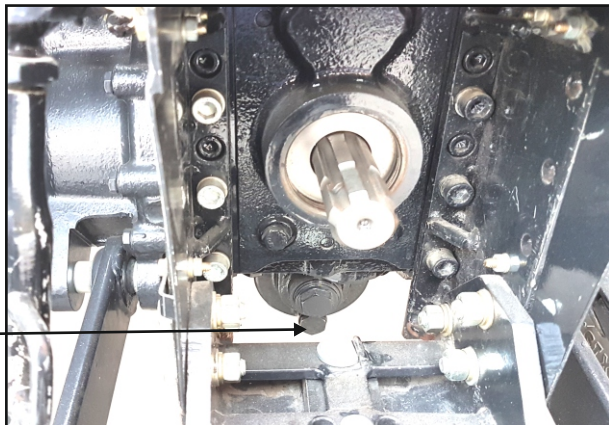

1. Transmission Drain Plug

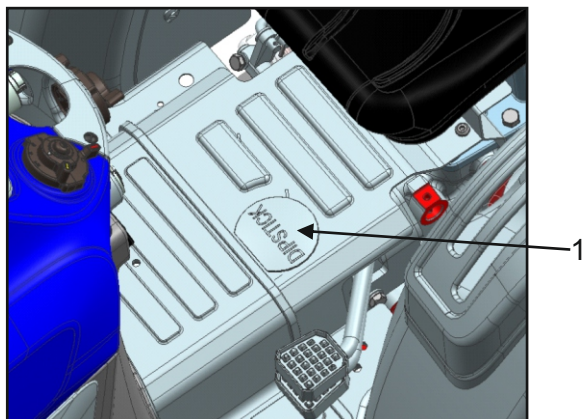

1. Transmission Dipstick

IMPORTANT:

- Do not operate the tractor immediately after changing the transmission fluid.

10.15 CHANGING FRONT AXLE CASE OIL

1. Park the tractor on a firm, flat and level surface.
2. To drain the used oil, remove the right and left drain plugs and filling plug at the front axle case and drain the oil completely into the oil pan.
3. After draining, reinstall the drain plugs.
4. Fill with new oil up to the upper notch on the dipstick. (See "LUBRICANTS" in "MAINTENANCE" section).

IMPORTANT:

After 10 minutes, check the oil level again and add oil to prescribed level.

5. After filling, reinstall the filling plug.
6. Properly dispose off used oil.

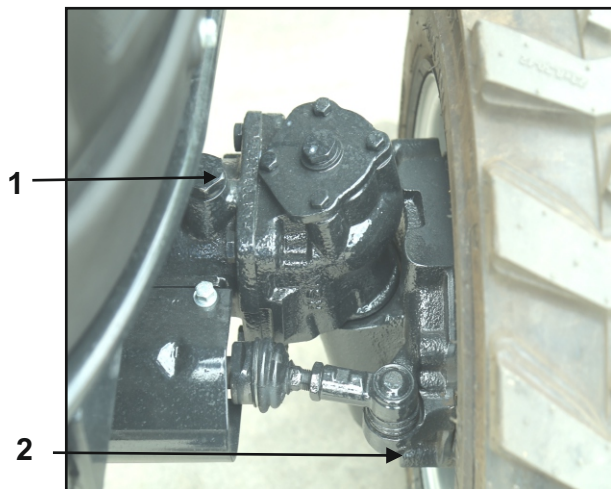

1. Filler Plug 2. Drain Plug

A blown fuse indicates that there is an overload or short somewhere in the electrical system.

If any of the fuses should blow, replace with a new one of the same capacity.

IMPORTANT:

- Before replacing a blown fuse, determine why the fuse blew and make any necessary repairs. Failure to follow this procedure may result in serious damage to the tractor electrical system. Refer to the "TROUBLESHOOTING" section of this manual or your local FARMTRAC Dealer / Distributor for specific information dealing with electrical problems.

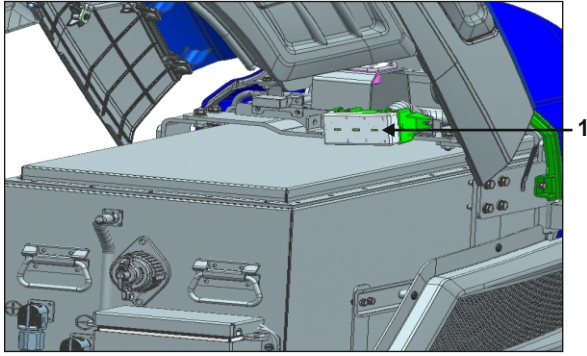

1 . Fuse Box

10.16 REPLACING LIGHT BULB

1. **Head lights.**
Take the bulb out of the light body and replace with a new one.
2. **Other lights**
Detach the lens and replace the bulb.

Light	Capacity
Head Light	55W
Tail / Turn Light	4.5W/4.5W
Hazard Light	4.5W/4.5W
Plough Light	55W
Beacon Light	55W

Recommended rust-preventive oil and corrosion inhibitor.

Table 9-1 Recommended rust preventive Oil and corrosion inhibitor

JIS No.		Recommended Product	Application
K2246	NP -3	Nippon Oil Corporation Anti Rust P-1400	Prevention of rust on exposed machine surfaces
	NP -10-2	Nippon Oil Corporation Anti Rust P-230	Prevention of rust on lubricating system

CHAPTER 11. TROUBLE SHOOTING

11.1. ERROR CODES FOR CONTROLLER AND BATTERY

Contact to your dealer / distributor if below mentioned controller or BMS error codes flashes on the instrument cluster.

MOTOR CONTROLLER ERROR CODE

S.No.	Error Code Description
12	Controller Over Current
13	Current Sensor Fault
15	Controller Severe Undertemp
16	Controller Severe Over temp
17	Severe B+ Under voltage
18	Severe B+ Overvoltage
18	Severe KSI Overvoltage
22	Controller Over temp Cutback
23	B+ Under voltage Cutback
24	B+ Overvoltage Cutback
25	+5V Supply Failure
28	Motor Temp Hot Cutback
29	Motor Temp Sensor Fault
31	Coil1 Driver Open/Short
31	Main Open/Short
32	Coil2 Driver Open/Short
32	EM Brake Open/Short
36	Encoder Fault
36	Sin/Cos Sensor Fault
37	Motor Open
38	Main Contactor Welded
39	Main Contactor Did Not Close
41	Throttle Wiper High
42	Throttle Wiper Low
43	Pot2 Wiper High
44	Pot2 Wiper Low
45	Pot Low Over Current
46	EEPROM Failure
47	HPD/Sequencing Fault
49	Parameter Change Fault
72	PDO Timeout
73	Stall Detected
83	Driver Supply
87	Motor Characterization Fault
51	Vehicle lock without applying hand brake
88	Encoder Pulse Count Fault
89	Motor Type Fault
92	EM Brake failed to set
99	Parameter Mismatch

BMS ERROR CODES

S.No.	Error Code Description
100	SOC is too high
101	SOC is too low
102	Total voltage is too high
103	Total voltage is too low
104	Charge current fault
105	Discharge current fault
106	Battery temperature is too low
107	Battery temperature is too high
108	Battery under voltage
109	Battery over voltage
110	Battery temperature unbalance
111	Battery voltage unbalance
112	The battery does not match
113	The temperature of the output pole is too high
116	The parameters of memory fault
117	Data memory fault
118	Cell voltage detection fault
119	Temperature detection fault
120	Current detection fault
121	Internal total voltage detection fault
122	External total voltage detection fault
123	Insulation monitoring fault
124	Clock fault
125	Internal CAN communication fault
126	Serious insulation fault
127	Slight insulation fault
140	System fault level
142	BMS fault need maintenance
143	Battery fault need maintenance
144	Battery system fault needs maintenance
145	The battery needs to maintenance (full charging and full discharging)
146	Maintenance mode status

11.2. TROUBLESHOOTING - GEARBOX, REAR AXLE AND FRONT AXLE

AGGREGATE	PROBLEM	CAUSE	ACTION
REAR AXLE	ABNORMAL NOISE	Improper backlash between Crown Wheel Gear & Pinion Shaft	Contact FARMTRAC Dealership
		Excess float in Differential Assembly	Contact FARMTRAC Dealership
		Differential Assembly Bearing wornout	Contact FARMTRAC Dealership
	NOISE WHILE TURNING	Differential washers wornout	Contact FARMTRAC Dealership
		Improper backlash between Differential Pinoin and Side Gear	Contact FARMTRAC Dealership
		Differential pinions gear or Side gears worn or damaged	Contact FARMTRAC Dealership
		Bull Gear / Pinion Shaft Teeth damage	Contact FARMTRAC Dealership
	DIFFERENTIAL LOCK NOT ENGAGING / DISENGAGING	Differential lock fork bent / damaged	Contact FARMTRAC Dealership
		Differential lock sleeve splines damaged	Contact FARMTRAC Dealership
	DIFFERENTIAL LOCK PEDAL DOESN'T RETURN	Differential lock fork guiding pin profile damaged / wornout	Contact FARMTRAC Dealership
		Rust in Differential Lock Linkage	Remove Rust or Contact FARMTRAC Dealership
	LEAKAGE FROM REAR AXLE	Seal Damaged	Contact FARMTRAC Dealership
	LEAKAGE FROM PTO SEAL	Seal Damaged	Contact FARMTRAC Dealership
	LEAKAGE / SEEPAGE FROM WELCH PLUG	Improper sitting of welch plug in bore	Contact FARMTRAC Dealership
LEAKAGE FROM PTO SHIFTING LEVER	Seal O Ring Damaged	Contact FARMTRAC Dealership	
BRAKE	ABNORMAL NOISE DURING BRAKING	Insufficient Oil	Fill Oil (Refer Instructions)
		Incorrect Oil Grade	Contact FARMTRAC Dealership
		Water Ingress in Oil	Contact FARMTRAC Dealership
	UNEVEN BRAKING FORCE	Uneven Brake Pedal Freeplay	Adjust - REFER INSTRUCTIONS
		Brake disc wornout	Contact FARMTRAC Dealership
	HIGH BRAKING FORCE REQUIRED TO STOP	High Freeplay in brake pedal	Adjust - REFER INSTRUCTIONS
		Brake disc worn-out	Contact FARMTRAC Dealership
		Actuator Assembly Worn-out	Contact FARMTRAC Dealership
	BRAKE DRAGS	Less Pedal Freeplay	Adjust - REFER INSTRUCTIONS
		Actuator Ball Cam profile wornout	Contact FARMTRAC Dealership
		Brake pedal return spring weaken or broken	Contact FARMTRAC Dealership
	4WD LEVER MOVE FREELY WHILE SHIFTING	Shifter ball struck	Contact FARMTRAC Dealership
	EXCESS NOISE IN HIGH GEARS	Not Recommended to operate in High Gears	Don't operate H1/2/3 in 4WD Mode

TROUBLESHOOTING - GEARBOX, REAR AXLE AND FRONT AXLE

AGGREGATE	PROBLEM	CAUSE	ACTION
4WD FRONT AXLE	DIFFERENTIAL NOT WORKING	- Differential Gear Broken	Contact FARMTRAC Dealership
	LEAKAGE FROM KNUCKLE HOUSING & KNUCKLE COVER	- Differential Gear Broken	Contact FARMTRAC Dealership
	LEAKAGE FROM KNUCKLE HOUSING & SWIVEL HOUSING	- Seal damaged	Contact FARMTRAC Dealership
	WHEEL END SHAFT NOT ROTATING OR JAMMED	- Internal Parts Damaged	Contact FARMTRAC Dealership
	LEAKAGE FROM WHEEL HOUSING	- Seal damaged	Contact FARMTRAC Dealership
	LEAKAGE FROM PINION SHAFT	- Seal damaged	Contact FARMTRAC Dealership
	LEAKAGE FROM REAR PILLOW BLOCK	- O'Ring damaged	Contact FARMTRAC Dealership
	SEEPAGE / GREASE COMES OUT FROM FRONT PILLOW BLOCK	- O'Ring damaged	Contact FARMTRAC Dealership
	LEAKAGE FROM RETAINER PINION SHAFT	- O'Ring damaged	Contact FARMTRAC Dealership
	EXCESSIVE FLOAT IN FRONT AXLE ASSEMBLY	- Bolt & nut not properly tightening	Adjust Play - Refer Instructions
	POWER NOT TRANSFER FROM REAR WHEEL TO FRONT WHEEL	- Propeller Shaft broken	Contact FARMTRAC Dealership
	EXCESSIVE NOISE	-Improper backlash b/w gears - Oil quantity insufficient - Bearing, Gears damaged.	Contact FARMTRAC Dealership
	FRONT WHEELS WANDER TO ONE DIRECTION	Uneven tyre Pressure	Check and correct air pressure
		Improper toe-in adjustment	Adjust - REFER INSTRUCTIONS
		Tie-rod end loose	Tighten - REFER INSTRUCTIONS
Air trapped in power steering		Bleed	
FRONT WHEEL DOESN'T ROTATE	Gear damaged	Contact FARMTRAC Dealership	
	Differential Gears damaged	Contact FARMTRAC Dealership	

TROUBLESHOOTING - GEARBOX, REAR AXLE AND FRONT AXLE

AGGREGATE	PROBLEM	CAUSE	ACTION
TRANSMISSION	TRACTOR STATIONARY AFTER ENGAGING GEARS	Input Shaft Circlip jump out	Contact FARMTRAC Dealership
	MAIN SPEED GEARS SELECTION NOT SMOOTH	Air vent hole plugged in shifting boot /sand, dirt at bush locations	Clear the vent hole in Shift Lever boot /Clean the parts from any sand or dust &
	SPEED GEAR LEVER DOESN'T SHIFT	Spring Tension Excess	Contact FARMTRAC Dealership
	TRACTOR STALLS / NOT MOVE AFTER ENGAGING GEAR	Interlock wornout / damaged	Contact FARMTRAC Dealership
		Circlip jump out from Input shaft	Contact FARMTRAC Dealership
	ABNORMAL NOISE	Oil level below Dipstick level	Fill Oil - Refer Instructions
		Gear / Bearing worn or broken	Contact FARMTRAC Dealership
	GEAR JUMP OUT	Detent spring damaged	Contact FARMTRAC Dealership
		Shifter Sleeve splines damaged/wornout	Contact FARMTRAC Dealership
		Fork Lugs bent	Contact FARMTRAC Dealership
	LEAKAGE / SEEPAGE FROM WELCH PLUG	Clearance in Plug/Hole or inclined assembly	Contact FARMTRAC Dealership
	LEAKAGE / SEEPAGE FROM COVER 4WD SHAFT	Seal Damaged	Contact FARMTRAC Dealership
	LEAKAGE / SEEPAGE FROM 4WD SHIFTING LEVER	Seal Damaged	Contact FARMTRAC Dealership



Escorts Kubota Limited

International Business Department

Plot No. 2 Sector-13, Faridabad - 121007, India

Phone : +91-0129-2575292/5507

E-mail : international@escorts.co.in

OFAGMCNEB1